

# GCL-MJ

MEDIUM-DUTY JACKSHAFT OPERATOR



The GCL-MJ is designed for high or full-lift sectional and rolling doors that have up to a 15-cycle/hour and less than a 50-cycle/day requirement. Advanced features and robust mechanical design combine to provide a medium-duty operator that is the new standard in the industry.

## UL 325 Listed

- Allows for monitored entrapment protection and momentary operation when used with select photoeyes and/or edge-sensing devices.

## GCL-MJ Advantages

- Rated for 15 cycles per hour operation, maximizing the performance of a medium-duty operator.
- Modular design with optional expansion boards for advanced close, edge sensing and auxiliary output functionality.
- Included internal Intellicode® receiver learns up to 50 transmitters with randomly assigned identity numbers. Learn and delete individual transmitters directly from LCD display.
- Ball bearing motor with built-in thermal protection and ball bearing drive end provides overload protection, extends motor life due to use of bearings over bushings, and isolates motor for quiet operation.
- Open/close/stop and setup keys included on control board. Keeps all controls near the LCD display convenient for set up.
- Electric box isolated from frame for reduced vibration.



## Standard Features

- EZ Limit® electro-mechanical limits.
- Max run timer automatically adjusts to up and down run time.
- TensiBelt® self-tensioning primary drive reduction.
- Delay on reverse.
- 16-character LCD display.
- UL 325 Listed.
- 3-button control station.
- 2-year/20,000-cycle warranty.
- Programmable mid-stop.
- Pull-cord release for emergency manual operation.
- Built-in cycle count and trouble-shooting assistance via LCD display.

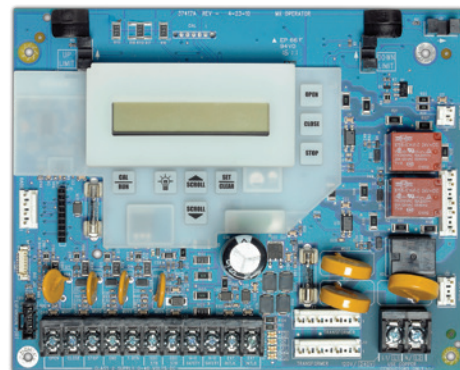

For more information on patents related to this product, visit <https://www.geniecompany.com/patents>.

©2025 The Genie Company | GCL-MJ



OFFICIAL GARAGE DOOR  
OPENER  
of the  
Pro Football Hall of Fame



# GCL-MJ | MEDIUM-DUTY JACKSHAFT OPERATOR

## MAX DOOR SIZE (SQ\*FT) - SECTIONAL

Door Series		Commercial Steel Insulated & Non-Insulated								Thermospan®				ThermoMark™			Aluminum		
		216	216 Ins.	220	220 Ins.	2415	2415 Ins.	2411	2411 Ins.	125	150	200	200-20	530	5150/5155	5200/5255	451/K-AL	452/464/K-AL	
		Flush		Ribbed						Insulated				Insulated					
Model	Max Door Wt. (lbs.)	16GA.	16GA. Ins.	20GA. Steel	20GA. Ins.	24GA.	24GA. Ins.	Nominal 24GA.	Nominal 24GA. Ins.	PU-FIP	PU-FIP 1.38"	PU-FIP 2"	PU-FIP 2" 20GA. Ext.	PU-FIP Ins. 3"	PU-FIP Raised Panel 1/38"	PU-FIP Raised Panel 2"	1/8" Glass 1.38"	1/4" or 1/2" Glass 1.38"	
1/2 HP	620	170	120	230	160	270	200	300	256	256	240	160	200	256	256	210	144		

## MAX DOOR SIZE (SQ\*FT) - ROLLING

Door Series		Steel Non-Insulated						Steel Insulated			Counter Doors		Grilles		FireStar® 2" Slat <sup>4</sup>		FireStar® 3" Slat Insulated <sup>4</sup>				Shutters	Sheet			
HP/ Voltage	Max Door Wt. (lbs.)	16 GA.	18 GA.	20 GA.	22 GA.	24 GA.	26 GA.	18 GA.	20 GA.	22 GA.	Aluminum	STL/ SST	Aluminum	STL/ SST	20 GA.	22 GA.	16 GA.	18 GA.	20 GA.	22 GA.	20 GA.	22 GA.	Aluminum	26 GA.	
1/2 HP	580	144	169	196	225	235	235	81	93	97	N/A	N/A	400	196	N/A	N/A	N/A	N/A	N/A	N/A	N/A	N/A	N/A	N/A	256

- Notes: 1. Max Door Weight and not the square footage, is the critical factor in selecting the proper operator.  
 2. Max Door Height 16'  
 3. For "Commercial Steel Insulated" category, various "backer" options are available. The chart above is based in all cases on the thickest backer available.  
 4. "PU-FIP" stands for "polyurethane, foamed-in-place." If no notation is present, insulation is "polystyrene laid-in-place."  
 5. GCL-MJ is UL Listed.

## Construction

- Motor**  
1/2 HP, 120 VAC capacitor start/run motor. Motor replaceable without changing limits.
- Brake**  
24 VDC disc brake.
- Drive**  
Primary — TensiBelt® auto tensioning poly-V J belt.  
Secondary — chain and sprocket reduction.
- Friction Clutch**  
Adjustable clutch to help protect against door and operator damage.
- Emergency Manual Operation**  
Pull-cord disconnect disengages drive allowing door to be moved manually while maintaining limits.
- Pre-wired to accept:**
  - Monitored entrapment devices.
  - Single or 3-button control stations.
  - External interlock switches.

## Accessories and Options

- Timer Close Module**  
Timer close set via the LCD display from 2 seconds up to 5 minutes. Includes pre-close warning contacts, timer hold input, auxiliary open input, normally closed safety input, and T3 monitored edge input (P/N: OPABTCGX.S).
- Auxiliary Output Module**  
Provides relay contacts at the open, close, and mid-stop limits. Contacts for 5-minute lamp, and "ADA" contacts set via LCD display to warn during opening, closing or both (P/N: OPABI0GX.S).
- Edge Sensing Module**  
Input allows connection of a T3 monitored safety edge. When advanced timer close features are required, use the Timer Close Module (P/N: OPABESX.S).
- UL 325 Approved Reversing Devices**  
The installation of a monitored external entrapment device is required for momentary contact close operation on all commercial door operators. The following devices, when purchased through Genie, are UL Approved for use to meet this requirement:
  - Safe-T-Beam® Photoeye Kit with adjustable bracket (P/N 38176R.S).<sup>1</sup>
  - Impact-protected Commercial Photoeye Kit (P/N OPAKPE2.S).
  - MillerEdge ME/MT/CPT (DC or T3) 2-wire edge sensor. Must be used with TCM (OPABTCGX.S), ESM (OPABESX.S), or Interface Module (OPAKMEIGX.S).
  - NEMA 4X Photocells (P/N: OPAKPEN4GX.S).
  - Retro-reflective NEMA 4X Photoeye Kit (P/N: OPGAKRPEN4X.S).
  - Monitored Light Curtains
    - 3 ft. length (P/N: OPAKMLC3.S).
    - 6ft. length (P/N: OPAKMLC6.S).
    - Light curtain mounting brackets (6 total) (P/N: 112809.0001.S).
- <sup>1</sup> — Default device when operator is ordered.
- Commercial Wi-Fi Module - Aladdin Connect®**  
This optional module plugs directly into the control board expansion port providing the operator with the ability to remotely monitor and control your commercial sectional garage door, with your smart device, from almost anywhere at any time while tracking the operation of your door. (P/N: OPAKCDM.S).

YOUR GENIE PROFESSIONAL DEALER:

AMPERAGE RATING 1PH 60Hz	
HP	120V
1/2	6.5

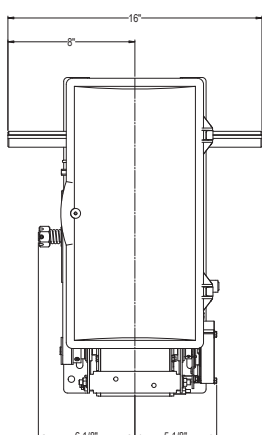
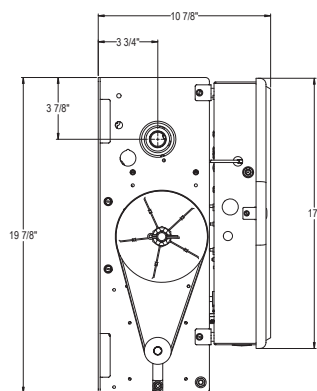

The Genie Company, One Door Drive, Mt. Hope, Ohio 44660

[www.geniecompany.com/commercial](http://www.geniecompany.com/commercial) | 1.800.843.4084

Item G001.0080 Rev. 12/24

© 2025 The Genie Company. Genie, Safe-T-Beam, Intellicode and the Genie logo, are registered trademarks of GMI Holdings, Inc., d/b/a The Genie Company. Consistent with our policy of continuing product improvement, we reserve the right to change product specifications without notice or obligation.