

# ALL-O-MATIC



## BLDC PRO

### OVERHEAD MANUAL



## OH-200DC PRO

**EACH INCLUDES:** QUICK RELEASE ARM

| 1 RED EYE 2 PHOTO EYE

**SLIDERS | SWINGERS | OVERHEADS**

The standard by which all other automatic gate operators are measured.

SCAN FOR  
PRODUCT  
INFORMATION



UL 325 2018  
COMPLIANT

UL 991  
COMPLIANT

CSA C22.2 #247



# TABLE OF CONTENTS

## **SAFETY AND INTRODUCTION**

Safety Instructions . . . . .	1-2
UL 325 Cass Types . . . . .	3
Operator Specifications . . . . .	4

## **INSTALLATION**

OH-200DC PRO Dimensions . . . . .	5
Operator Installation . . . . .	6
Mounting Instructions. . . . .	7
Electrical connection . . . . .	8
Opening Direction and Gate Travel Adjustment. . . . .	9

## **BOARD FEATURES**

DIP Switch Functions. . . . .	10
Auto Close Timer Setting and Radio Receiver Wiring . . . . .	11
Electronic Reversing Device (ERD) Adjustment . . . . .	12
Programmable Relay and Leaf Delay Settings . . . . .	13

## **WIRING ACCESSORIES TO CONTROL BOARD.**

Monitored Entrapment Protection Device Installation. . . . .	14-17
Loop Rack Detector Installation . . . . .	18-19
Accessory Connections . . . . .	20-21

## **SOLAR INSTALLATION**

Solar Panel Connection . . . . .	22-23
----------------------------------	-------

## **TECHNICAL**

LED Diagnostics . . . . .	24
Technical Tips (troubleshooting) . . . . .	25
Aux Input 1 & 2 Programming . . . . .	26
LCD Settings and Diagnostics . . . . .	27-28

## **EMERGENCY RELEASE INSTRUCTIONS.**

	29
--	----

## **BREATHING CAP PIN.**

	30
--	----

## **WARRANTY AND CUSTOMER RECORD.**

	31
--	----

## **PARTS BREAKDOWN**

OH-200DC PRO Blowout Drawing . . . . .	Check Website
--	---------------

# IMPORTANT SAFETY INSTRUCTIONS

## **WARNING**

TO REDUCE THE RISK OF **INJURY**:

**READ AND FOLLOW ALL INSTALLATION INSTRUCTIONS. DO NOT START INSTALLATION UNTIL YOU HAVE READ AND UNDERSTAND THESE DIRECTIONS. IF THERE IS SOMETHING YOU DO NOT UNDERSTAND, PLEASE CALL US.**

**NEVER** let children operate or play with gate controls.

Locate the control station and make sure it is (a) within sight of the gate and (b) at a minimum height of 5 feet so small children cannot reach it.

Install the enclosed entrapment warning signs next to the control station and in a prominent location.

For operators equipped with a manual release, instruct the end user on the correct operation of the manual release. Use the manual release only when the gate is not moving. It is advised that the power be turned off.

Always keep people and objects away from the gate. No one should cross the path of a moving gate.

The gate operator must be tested monthly. The gate must reverse on contact with a rigid object, or stop when an object activates the non-contact sensor(s). Always re-test the operator after adjusting the limits and/or force. Failure to adjust and re-test the gate operator properly may cause severe injury or death.

Keep gate(s) properly maintained. Have a qualified service technician make repairs to gate hardware and make proper adjustments to gate operator.

This gate entrance/exit is for vehicles only. Pedestrians must use a separate entrance.

There is nothing on a gate operator that is easily repaired or adjusted without a great deal of experience. Call a qualified gate service technician who knows your gate operator.

## SAVE THESE INSTRUCTIONS

## INSTALL THE GATE OPERATOR ONLY WHEN YOU HAVE READ THE FOLLOWING

### BEFORE GATE OPERATOR INSTALLATION

- Confirm that the gate operator being installed is appropriate for the application.
- Confirm that the gate is designed and built according to the current published industry standards.
- Confirm that all appropriate safety features and safety accessory devices are being installed, including all entrapment protection devices.
- Make sure that the gate opens and closes freely (by hand) before installing the operator.
- Repair or replace worn or damaged gate hardware before installing the gate operator.
- Eliminate all gaps in the sliding gate below a 6 foot height that permits a 2 1/4" sphere to pass through any location. This includes the area of the adjacent fence covered when the gate is in the open position
- Eliminate all gaps in a swing gate below a 4 foot height that permits a 4" sphere to pass through any location. This includes the hinge area of the gate.
- Install a proper electrical ground to the gate operator.
- Controls intended for user activation must be located at least 6 feet away from any moving part of the gate, and where the user is prevented from reaching over, under, around, or through the gate to operate the controls.
- Outdoor or easily accessible controls shall have a security feature to prevent unauthorized use.
- The stop and/or reset button must be located in the line of sight of the gate. Activation of the operator reset control shall not cause the operator to move.
- Install a minimum of 2 warning signs, one on each side of the gate where they are easily visible.
- Take pictures of the installation.
- Test all safety features for proper function before placing the automatic vehicular gate in operation.

### GATE OPERATOR INSTALLATION

- Operator must be disconnected from the power source before attempting any installation of accessories.
- Install gate operator according to the installation instructions in this manual.
- Adjust the operator clutch or load sensing device to the minimum force setting that will allow for reliable gate operation.
- Install the operator inside the fence line. Do not install the operator on the public side of the fence line.

### MAINTENANCE

- Train owners/users on the basic functions and safety features of the gate system, including how to turn off the power and operate the manual disconnect feature.
- Leave safety instructions, product literature, installation manual, and maintenance manual with the owner or end user.
- Explain to the owner or end user the importance of routine service and operator testing on a monthly basis.

Each class must have (2) monitored entrapment protection devices in each entrapment zone to sense and react to obstructions within 2 seconds.

All-O-Matic's gate operators conform to the most rigid Class One.

## UL 325 CLASS TYPES

### **CLASS ONE: RESIDENTIAL**

- A vehicular gate operator intended for use in garages or parking areas associated with a residence of one to four single families.

### **CLASS TWO: COMMERCIAL OR GENERAL PUBLIC ACCESS**

- A vehicular gate operator intended for use at a commercial location or building, such as a multi-family housing unit (five or more single family units), hotel, garages, retail stores, or other buildings accessible by or servicing the general public.

### **CLASS THREE: INDUSTRIAL OR LIMITED ACCESS**

- A vehicular gate operator intended for use at an industrial location or building, such as a factory, loading dock area, or other locations not accessible by or intended to service the general public.

### **CLASS FOUR: RESTRICTED ACCESS**

- A vehicular gate operator intended for use at a guarded industrial location or building, such as airport security areas or other restricted access locations not servicing the general public and where unauthorized access is prevented via supervision by security personnel.

## THE SIX TYPES OF OBSTRUCTION SENSING SYSTEMS

### **TYPE A:**

- Inherent entrapment protection system. This system must sense and initiate the reverse of the gate within 2 seconds of contact with a solid object.

### **TYPE B1:**

- Non-contact sensor (photoelectric sensor or equivalent). This system shall, upon sensing an obstruction in the direction of the gate travel, reverse the gate within a maximum of 2 seconds.

### **TYPE B2:**

- Contact sensor (edge device or equivalent). This system shall, upon sensing an obstruction in the direction of the gate travel, initiate the reversal of the gate within a maximum of 2 seconds.

### **TYPE C:**

- Inherent force limiting, inherent adjustable clutch, or pressure relief valve.

### **TYPE D:**

- Actuating device requiring continuous pressure to maintain opening or closing motion of the gate.

# OPERATOR SPECIFICATIONS

	<b>OH-200DC PRO</b>
<b>Max Gate Weight</b>	800 lbs.
<b>Max Gate Length</b>	22'
<b>Warranty</b>	5 year commercial
<b>Motor</b>	24 VDC brushless 1/2 HP equivalent
<b>Gate Speed</b>	Approximately 15 seconds per opening 6.5' - 8' high gate
<b>Power</b>	115 VAC single phase - 6 amps 230 VAC single phase - 3.5 amps or 24 VDC solar panel up to 80 watts
<b>Duty Cycle</b>	Continuous
<b>Temperature Range</b>	-40° to 160°
<b>Gear Box Ratio</b>	40:1
<b>Dimensions</b>	13" W X 144" L X 8" H (Custom rail lengths available)
<b>Shipping Weight</b>	110 lbs.
<b>Emergency Release</b>	Lockable quick release drive arm and carriage
<b>Belt Size</b>	4L-200
<b>Main Sprocket</b>	41B15 x 5/8" bore
<b>Chain Size</b>	41NP
<b>Gear Box Sprocket</b>	N/A
<b>Limit Shaft Sprocket</b>	N/A
<b>Breaker Requirement</b>	20 amp dedicated
<b>Gearbox Pulley</b>	2.5" with 1/2" bore
<b>Motor Pulley</b>	2" with 5/8" bore
<b>UL Classes</b>	I, II, III & IV

# OH-200DC PRO DIMENSIONS

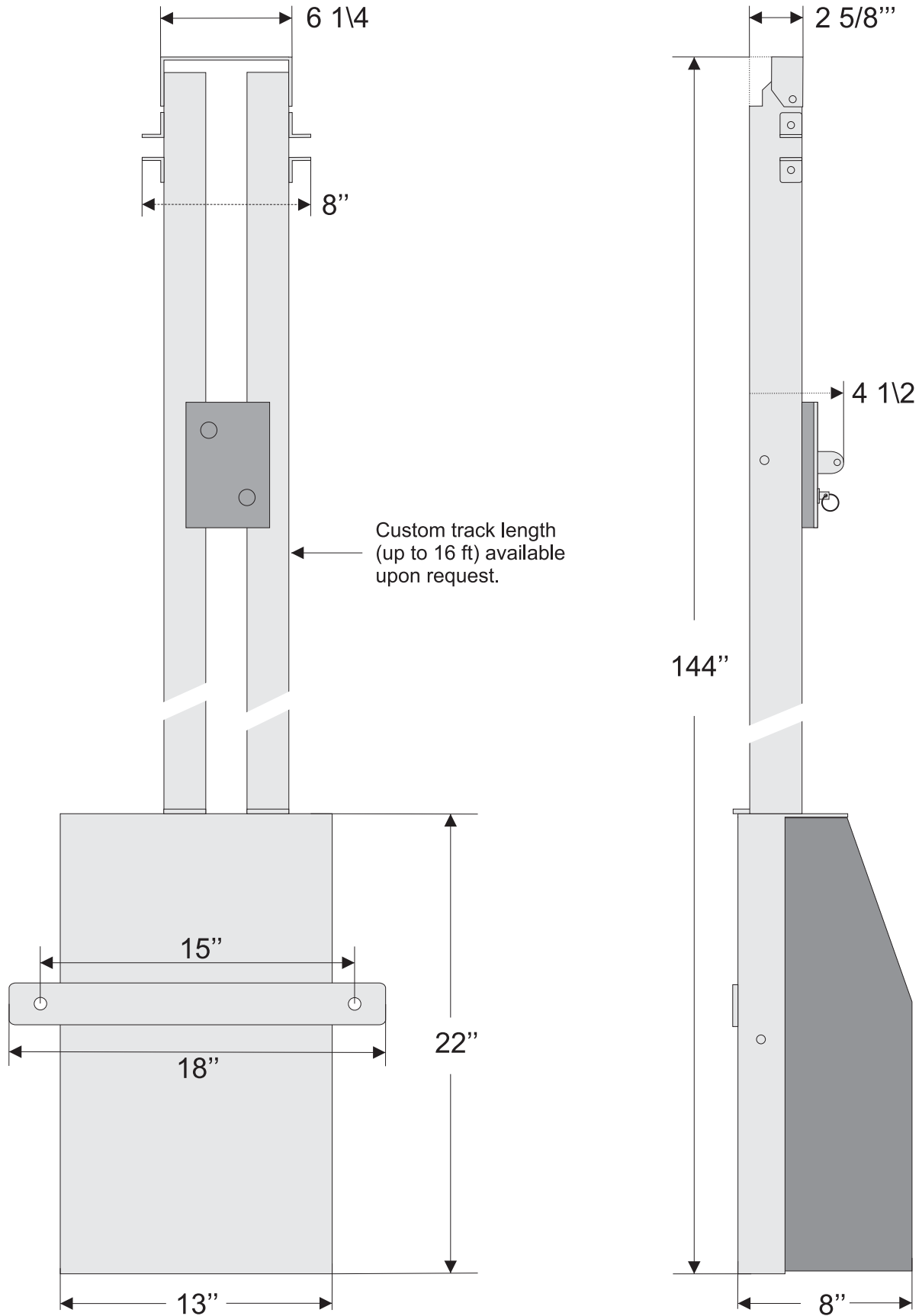

# OPERATOR INSTALLATION

**Note:** Make sure the gate hardware is well balanced. The gate should open and close smoothly.

With gate closed, mark the center of the gate.

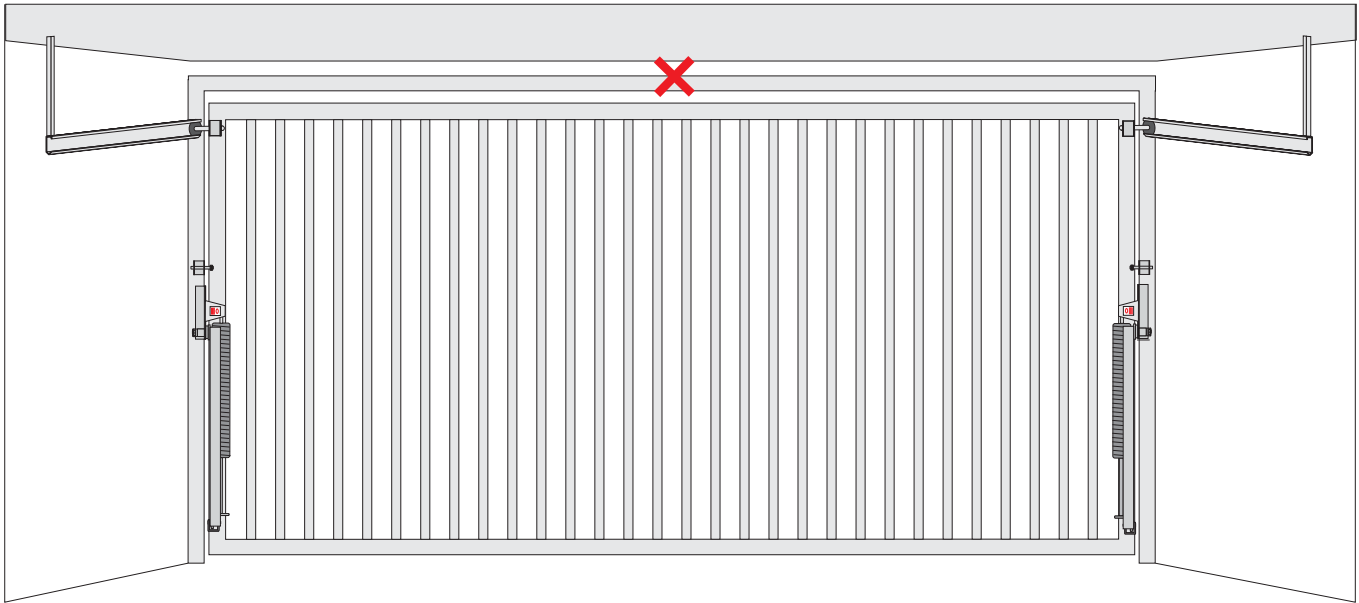

Lift gate to open position and mark the center point of the gate for the operator on the ceiling.

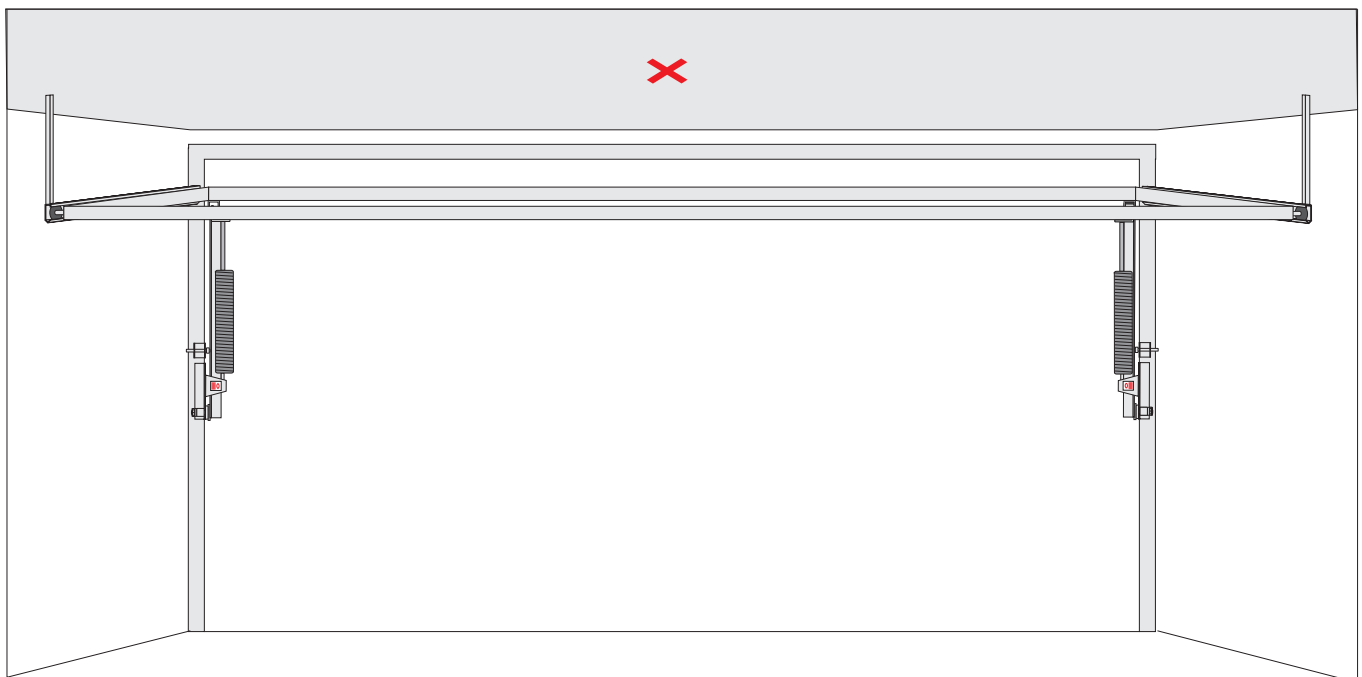

# MOUNTING INSTRUCTIONS

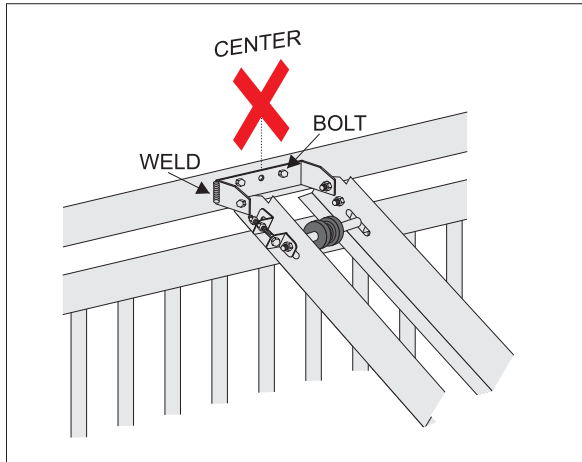

Make sure the end bracket is in the center of the opening. Bolt or weld the end bracket to wall. The operator bracket must be at least 2.5" above the gate.

Level and align the gate operator tracks before mounting them to the ceiling. Manufacture ceiling brackets to weld or bolt the operator in place (not provided).

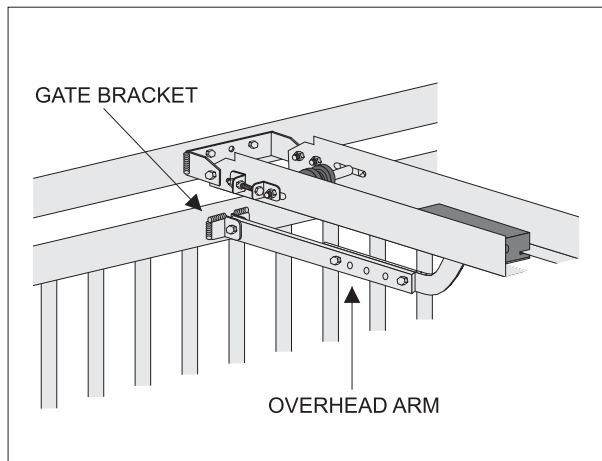
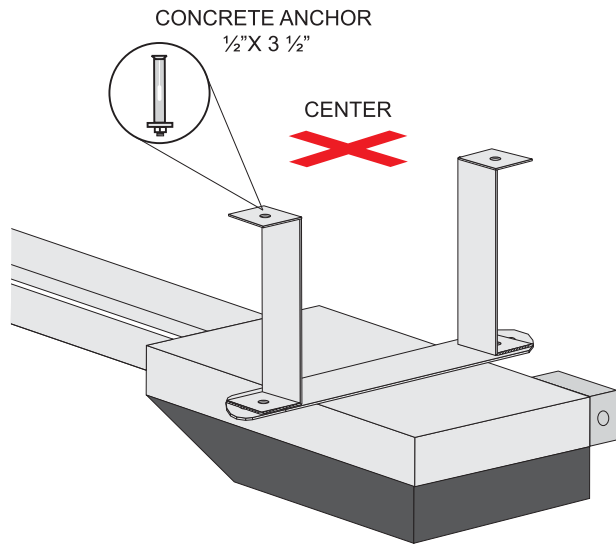

Connect the overhead arm, insure alignment, and weld the gate bracket in place.

# ELECTRICAL CONNECTION

## OPERATORS **MUST** BE PROPERLY GROUNDED!

- All gate operators **MUST** be properly grounded. This minimizes or prevents damage due to electrical charge, such as a near lightning strike or an electrical static discharge.
- Use a single wire for the ground. **DO NOT** splice two wires for the ground. If the wire breaks or is cut, replace it with a single length wire. **NEVER** use two wires for the ground.
- **Check the local city code for proper earth ground rod type and grounding procedures. As it is crucial to have the proper lightning protection on control board.**
- Use UL listed conduits for power wire enclosure.
- These operators have the option to be powered from a 115VAC or 230VAC single phase. In the EMI board use the voltage selector switch for the voltage option. See table below for wiring incoming power.
- Use a minimum of a 20Amp, dedicated circuit for each operator.
- See current draw table to calculate power wire size.

DC PRO GATE OPERATORS	CURRENT DRAW @ 115VAC	CURRENT DRAW @ 230VAC
OH-200DC PRO	6 AMPS	3.5 AMP

Use above operator current draw table and the tables on next page to help you calculate the power wire size for the run.

It is important to use the correct size wire to avoid large voltage drops.

**IMPORTANT:** Due to the dual voltage option (115VAC/230VAC single phase), the receptacle neutral is separate from the neutral wire to the EMI board. The white wire connected to the receptacle neutral must be connected to the neutral wire of the EMI board when 115VAC power is used. **DO NOT** connect this receptacle white wire when 230VAC is used. This will cause damage to devices plugged to receptacle.

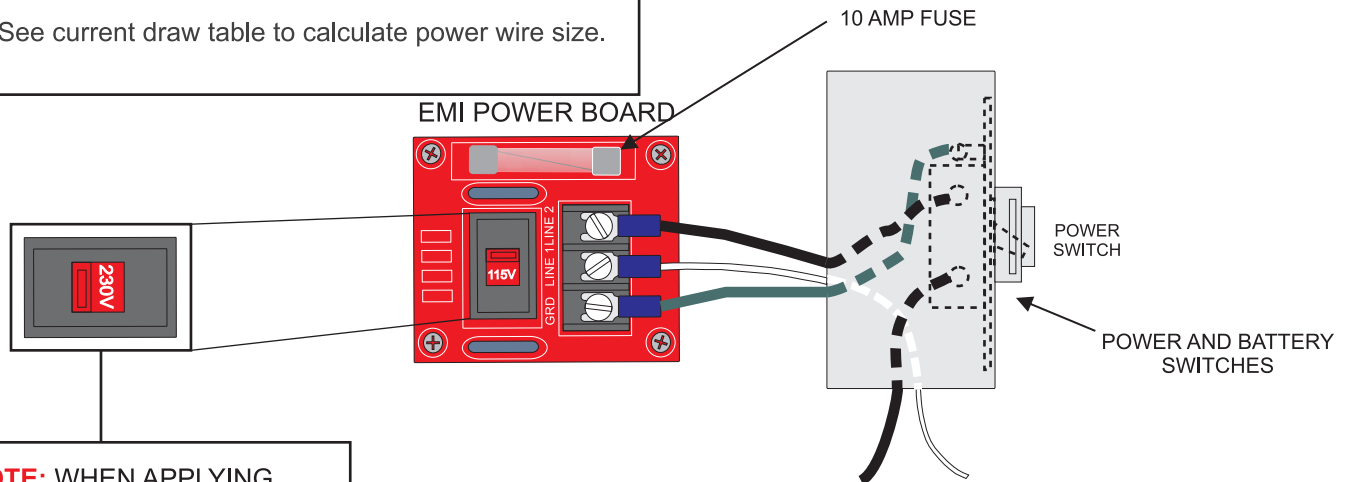

**NOTE:** WHEN APPLYING 230V TO THE OPERATOR, MAKE SURE VOLTAGE SWITCH IS FLIPPED TO 230V

Power Connection	115 VAC 50/60Hz	230 VAC 50/60Hz Single Phase
LINE 1	115V HOT	230V LINE 1
LINE 2	115V NEUTRAL	230V LINE 2
GND	GROUND	GROUND

**CAUTION:** Before wiring high voltage, be sure to turn OFF the breaker.

# GATE DIRECTION & TRAVEL ADJUSTMENT

## DIP-SWITCHES



LED indicators will indicate opening or closing when the gate is in motion

## OPENING DIRECTION SETTING

- Use OPEN L/R” dipswitch (#8) to change the opening direction of the operator.
- LEDs will show opening and closing direction when the gate is moving.
- OPEN L/R switch should be set to “ON” for the OH-200DC PRO gate operator.

## GATE TRAVEL ADJUSTMENT

Locate the limit switches and follow the steps below:

- 1: Stop the gate operator in the desired position using the 3 button station on the control board. Turn the power **OFF** to the operator.
- 2: Push the limit lock plate down.
- 3: Turn the limit nut toward the switch to **DECREASE** travel and away from the switch to **INCREASE** travel.
- 4: Place limit plate back to its locked position. (**MUST** be done for gate to hold its limits)
- 5: Turn the power **ON** to the operator.
- 6: Run the gate operator open and close. If additional adjustment is needed, repeat the steps.

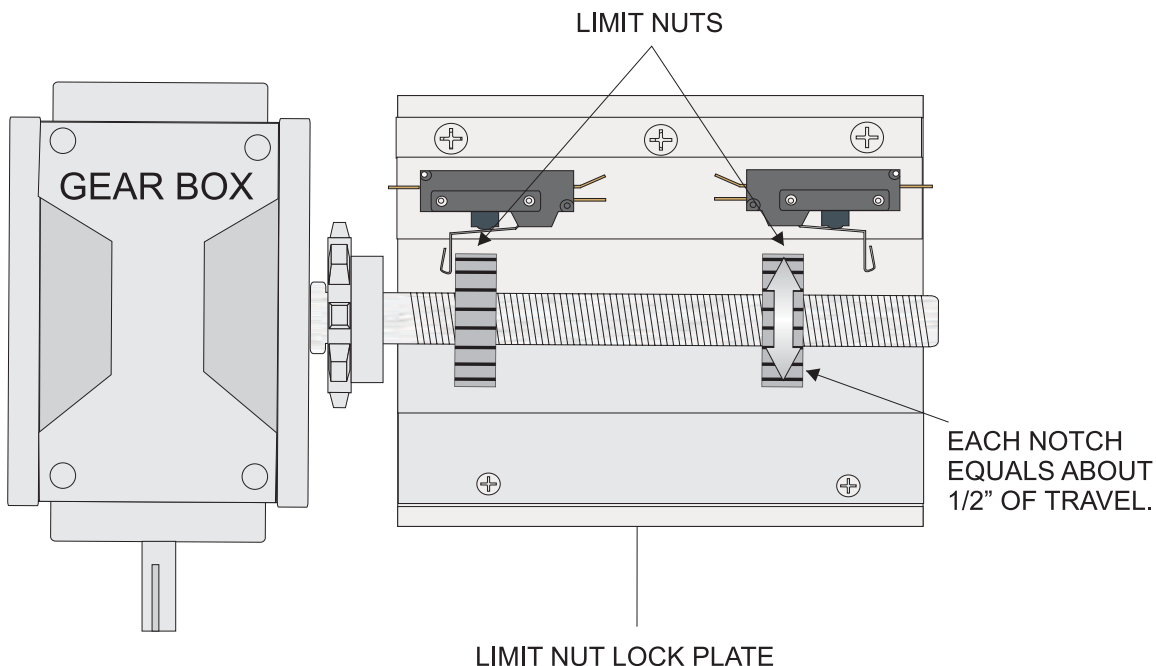

# DIP SWITCH FUNCTIONS

## TIMER

**TIMER** switch “ON” activates the automatic close timer. See page 21 for details.

## RADIO

**RADIO** switch “ON” allows the radio receiver to override the automatic close timer. See page 21 for details.

## OSC

**OSC** switch “ON” allows the radio receiver to stop and reverse the gate in any direction. During a cycle, the first signal stops the gate. A second signal reverses the gate.

## FAIL SC/SF

**ON** for **Fail-Safe**: Upon power failure, board will monitor battery voltage to make sure gate opens before battery completely drains. **OFF** for **Fail-Secure**: Upon power failure, gate will run until battery is low and lock closed.

## 1-PASS

**1-PASS** switch “ON” allows the gate to open until one vehicle goes over the safety loop. Once the vehicle has cleared the loop, the gate will stop and close. If a second vehicle goes over the loop while the gate is closing, the gate will stop. The vehicle must get off of the loop before the gate continues to close, forcing the second vehicle to present valid credentials. This is a true one pass, anti-tailgating feature to be used with safety loops.

## SECONDARY

This feature is used in dual gate applications. The **SECONDARY** switch will be “ON” only on the secondary operator. All other dip switches will be “off”, except the OPEN L/R. **SECONDARY** switch will be “OFF” on the primary operator (feature not common for Overhead).

## AUTO OPEN

This feature is to automatically open the gate on power interruption. It is a very particular feature used in areas where the fire department requires the gate to open automatically after a power outage.

Set this dip switch “ON” when this feature is desired.

NOTE: There is a 40 second delay between power outage and the gate opening.

## OPEN L/R

**OPEN L/R** switch Should be set to “ON” for OH-200DC PRO for proper direction.

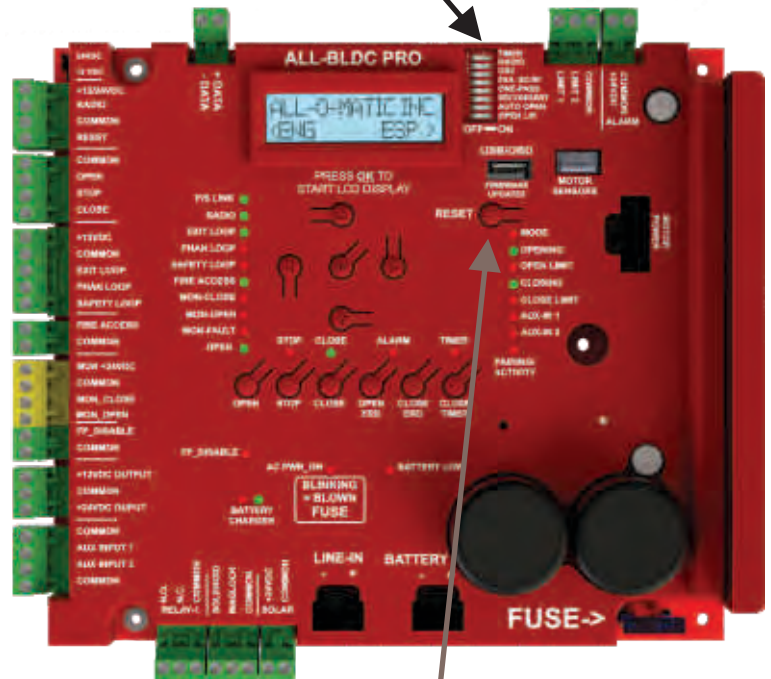
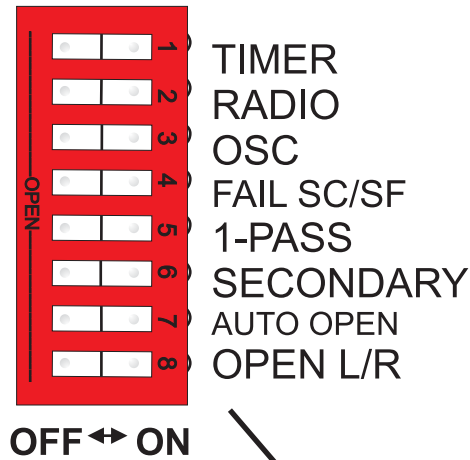

**NOTE:** IF ANY CHANGES ARE MADE TO THE DIP-SWITCHES, PRESS THE **MAIN RESET** BUTTON TO RECOGNIZE THE CHANGES.

# AUTO CLOSE TIME SETTING & RADIO RECEIVER WIRING

## AUTO CLOSE TIMER SETTINGS

**TIMER ON:** Automatic timer to close can be set from 1 to 120 seconds (2 minutes)

**TIMER OFF:** Gate operation is “push button to open, push button to close”

**RADIO ON:** Use this option to override the timer and allow the transmitter to close gate before auto close timer does.

**OSC ON:** Use this option to use the remote/transmitter to stop the gate mid cycle (just like a garage door opener). 1. press remote once, gate starts to run. 2. press it a second time to stop gate. 3. press it a third time to reverse the gate.

To activate and adjust the timer, set the **TIMER** dip-switch to the **ON** position, then press the **TIMER** push button to open the **TIMER** adjustment in the LCD display.

Once, the display shows the **TIMER** adjustment, use the **UP** and **DOWN** push buttons to set the number of seconds the gate will remain open before it closes automatically.

### TIMER, RADIO & OSC dip-switches



TIMER quick access button

## RADIO RECEIVER WIRING

There are two types of receivers: 3-wire and 4-wire:

3 wire receivers can mount on the radio receiver terminal strip located outside of the control box.

For 4 wire receivers, connect the relay contact wires to terminals 1 (COMMON) and 2 (RELAY/RADIO) on the receiver terminal strip located outside of the control box (one wire on each terminal). For power connect the black(negative) wire to terminal 1 (COMMON) and the red (positive) wire to terminal 3 (+12/24VDC) on the receiver terminal strip as shown below.

RADIO dip switch ON allows the radio receiver to override the automatic close timer. See **TIMER** adjustment above for more details.

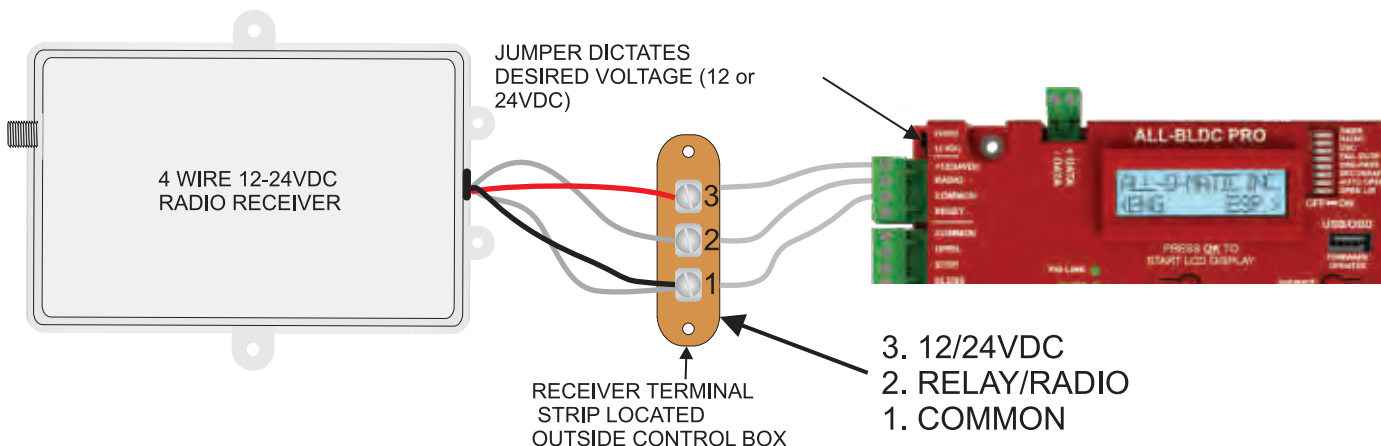

# ELECTRONIC REVERSING DEVICE (ERD) ADJUSTMENT

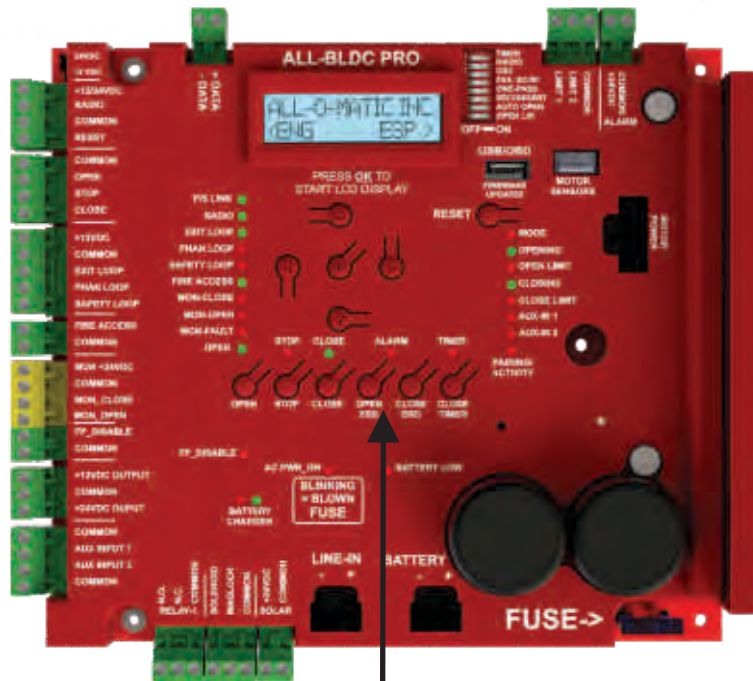

ERD quick access buttons

ALL-BLDC PRO boards are equipped with an Electronic Reversing Device (ERD), which will cause the gate to reverse direction when it comes in contact with an obstruction.

The amount of force required to reverse the gate's direction depends on the ERD force setting.

The ERDs must be adjusted for the operator to provide regular, reliable & safe operations. If the gate reverses direction on its own without hitting an obstruction, the ERD force is too low. If the gate does not reverse when it hits an obstruction, the ERD force is set too high.

The gate operator ERDs shall be tested and adjusted every six months by a qualified technician.

To adjust OPEN or CLOSE ERDs, we have included quick access buttons that open up the menu without the need to navigate through the menu to get to the adjustment.

Follow these steps to adjust each direction individually.

1. As the gate is opening, press and release the OPEN ERD button. The OPEN ERD adjustment will open up in the LCD display. Use the DOWN button to decrease the force. When force is low enough for the gate to stop and reverse, increase the force by 30%. Example: if the gate reversed when force was at 20%, increase the force to 50%. The 30% will be the buffer to allow the operator to run the gate reliably and safe to react to obstructions.

2. As the gate is closing, press and release the CLOSE ERD button. The CLOSE ERD adjustment will open up in the LCD display. Use the DOWN button to decrease the force. When force is low enough for the gate to stop and reverse, increase the force by 30%. Example: if the gate reversed when force was at 20%, increase the force to 50%. The 30% will be the buffer to allow the operator to run the gate reliably and safe to react to obstructions.

NOTE: From factory, the OPEN and CLOSE ERDs force is set to 50%.

# PROGRAMMABLE RELAY AND LEAF DELAY

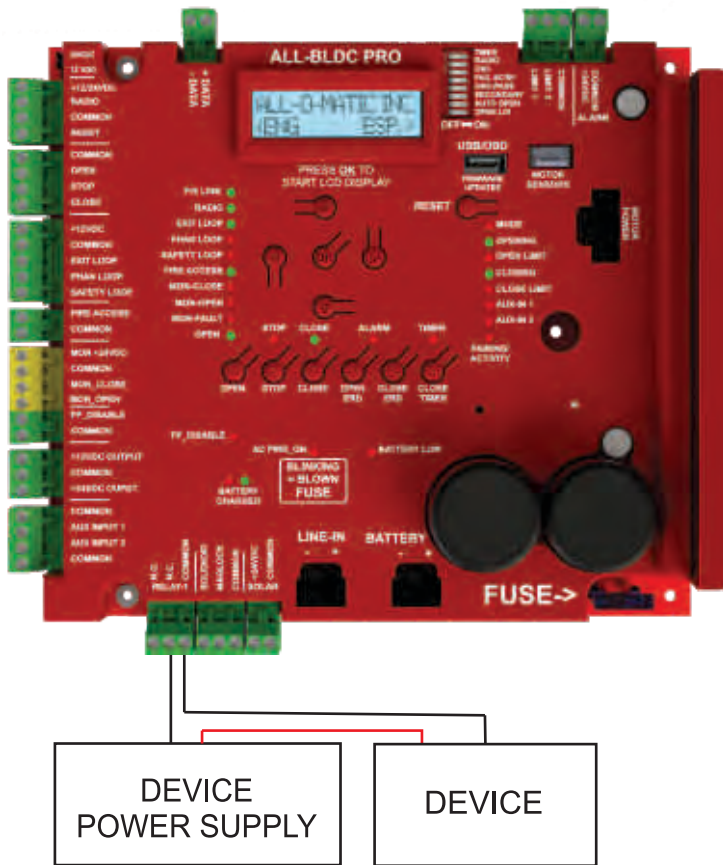

## ENTERING LCD DISPLAY MENU

To wake up the display, press OK button twice. The message shown on image will be displayed. Press < left button to start English menu. From there, you can press OK button while cursor is on SETTINGS option. In there you can find the settings for the setting below, AUXILIARY RELAY and LEAF DELAY.

Use UP or DOWN buttons to scroll through menu items.  
Use < LEFT button to go to previous menu.

## RELAY-1 SETTINGS

ALL-BLDC PRO includes a programmable relay (N.O. or N.C.) with four different configurations. Using the LCD display menu, relay can be programmed for one of 4 different options. Navigate to menu setting Auxiliary Relay. To get there, go into English menu, go into SETTINGS, then scroll down to AUXILIARY RELAY, press OK. In there you can find the following options.

- (1) PRE-WARN SIGNAL: Use this option to control an alarm, or strobe light to pre-warn people the gate will move. In this setting, there can be a delay set to start the alarm or strobe before gate starts to move.
- (2) MOVING SIGNAL: To activate the relay when ever the gate is in motion. This function is similar to first option, except no delay.
- (3) OPENED SIGNAL: With this option, relay will be activated whenever the gate is fully open. It could be for an indicator for end user to see the position of gate.
- (4) CLOSED SIGNAL: With this option, relay will be activated when gate is fully closed. It could be for an indicator for end user to see the position of gate.

## DELAY SETTINGS

ALL-BLDC PRO control boards includes a delay option for open or close cycles. This delay option is most commonly used on swing gate applications. To activate this delay, navigate to the menu setting LEAF DELAY. To get there, go into English menu, go into SETTINGS, then scroll down to LEAF DELAY, press OK. In there you'll find the following.

DELAY CLOSE ^  
DELAY 00.0SEC.

While the cursor is on first line DELAY CLOSE, press OK button to change the delay direction. While in this setting, use the UP button to toggle/change from CLOSE to OPEN. Once you have the desired delay direction displayed, press OK button. Scroll down to DELAY and press OK button. In here, you will see one line displayed saying DELAY and the seconds. Using up and down buttons, adjust the delay. Once you have the desired delay displayed, press OK button to save.

If you have a secondary operator, repeat the process on it but set the delay for the opposite direction.  
**Important: Delay can be set for one direction only.**

# ENTRAPMENT PROTECTION INSTALLATION

- A minimum of (2) monitored entrapment protection devices are **REQUIRED** for each entrapment zone.
- An entrapment zone is a location or point of contact where a person can become entrapped between a moving gate and a rigid object.
- The operator is equipped with an inherent entrapment protection system (ERD).
- The gate operator requires an external monitored entrapment protection device (non-contact photoelectric sensor or contact edge) for each entrapment zone prior to gate operation. The operator cycles power to the external entrapment protection device and checks for device signals. If the operator does not receive the correct feedback from the device, the gate will not operate.

## OUTSIDE PROPERTY LOOKING IN

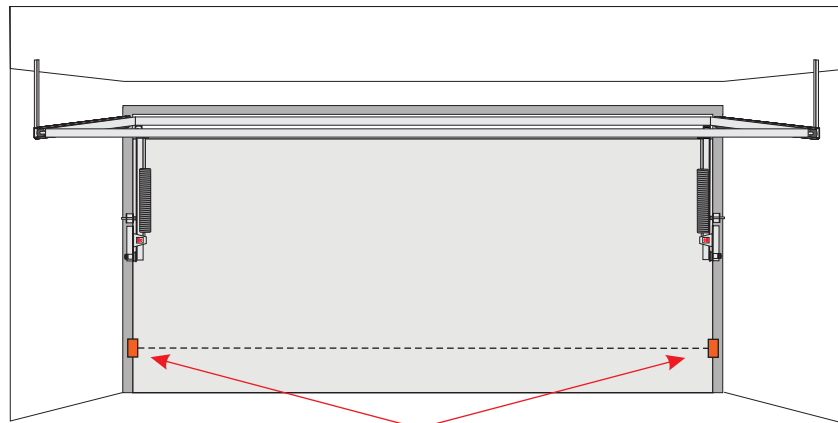

PHOTOELECTRIC SENSOR FOR CLOSE CYCLE

## SIDE VIEW

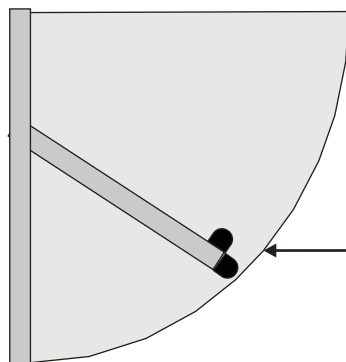

EDGE SENSOR FOR OPEN CYCLE. INSTALL HORIZONTALLY ON BOTTOM AND/OR FRONT OF GATE FRAME

# MONITORED ENTRAPMENT PROTECTION DEVICE WIRING

## WIRING ENTRAPMENT DEVICE TO DC BOARD

### WIRING DEVICE ACROSS DRIVEWAY / CLOSE DIRECTION (MON\_CLOSE)

WIRING THE AOM-RED-EYE (INCLUDED WITH OPERATOR) TO THE CIRCUIT BOARD

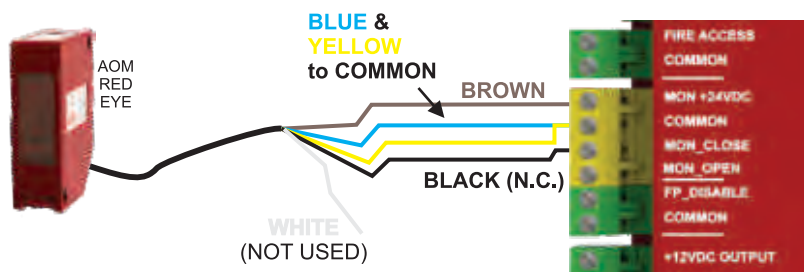

### WIRING DEVICE FOR OPEN DIRECTION (MON\_OPEN)

WIRING THE AOM-RED-EYE (NOT INCLUDED WITH OPERATOR) TO THE CIRCUIT BOARD

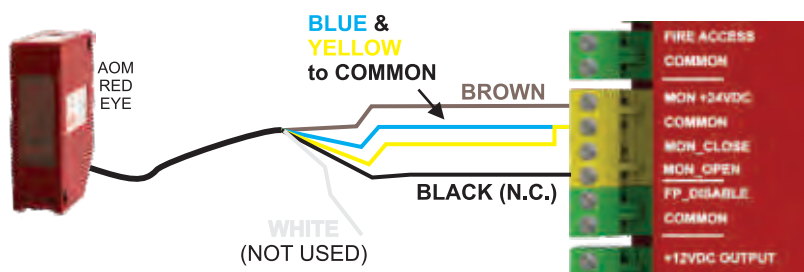

ALL-BLDC PRO offers the 10K termination alternate option. Connect 10K sensor contacts to COMMON and MON-OPEN or MON-CLOSE as shown below.

Close contact edge with 10K termination

Open contact edge with 10K termination

**Additionally,** AUX INPUT 1 and 2 can be used to wire additional entrapment protection devices (10K or N.C. termination). For N.C. devices, power must be connected to MON +24VDC. For 10K devices power could be connected to the constant +12VDC or +24VDC if it requires power. See LCD display page for details of programming inputs.

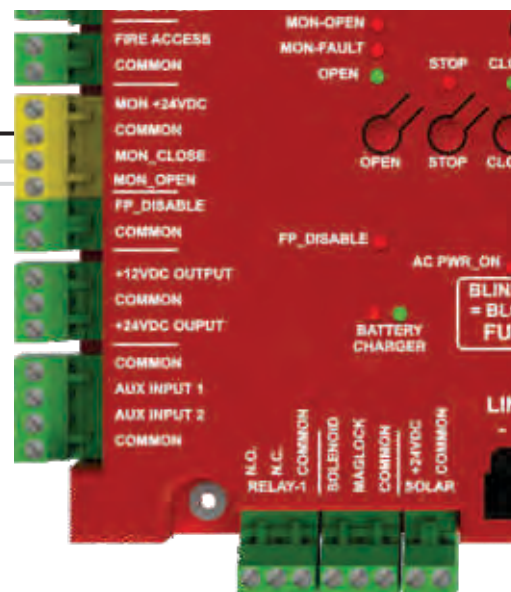

# 3RD PARTY MONITORED ENTRAPMENT PROTECTION DEVICE CONNECTIONS

- There are 2 types of sensors that can be connected to the gate operator for UL 325 monitored entrapment compliance: non-contact sensors (photo eye) and contact sensors (edge sensors).
- Monitored entrapment protection devices use 4 wires to connect to the board. From the device, connect the **RELAY COMMON** to the board **COMMON** and the **NORMALLY CLOSED** relay contact to the assigned **MON\_OPEN** or **MON\_CLOSE** input. **MON +24VDC** and **COMMON** must be used to power these devices and properly monitor the them.
- **IMPORTANT:** ALL-BLDC PRO can also work with 10K termination devices. See bottom of previous page for wiring details.
- **NOTE:** The power to the **MON +24VDC** terminal will be off when the gate is at rest (not moving). It will be normal to see the **MON\_OPEN** and **MON\_CLOSE** LEDs when the gate is closed. If the auto close timer is **OFF** it will do the same when the gate is at rest in the open position. Also, if no devices are connected both of these lights will stay ON.
- Please refer to the device manufacturer wiring instructions for details (on next page), making sure to follow the normally closed wiring directions. Some devices may work on monitoring interfaces other than normally closed.
- Should there be a need for more than 1 entrapment protection device for each direction, **AUX INPUT 1** and **AUX INPUT 2** could be used as MONITORED input expansion. See LCD display page for programming details.

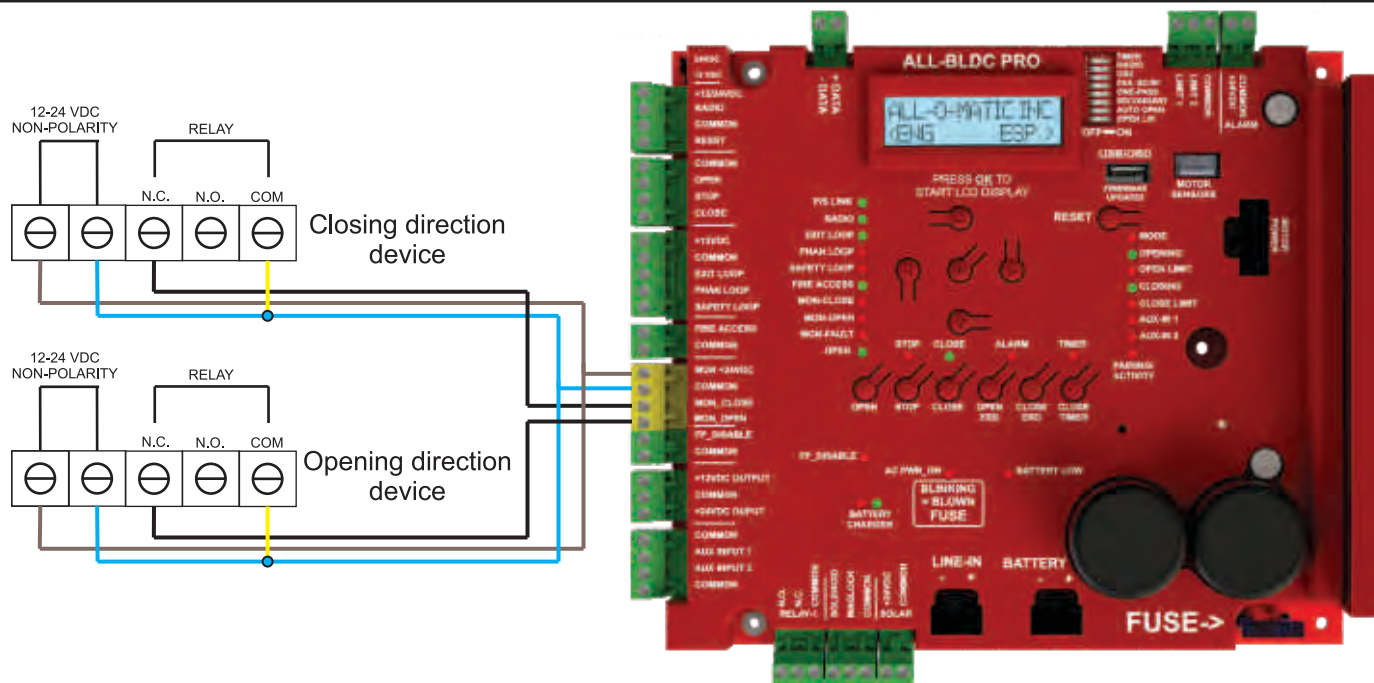

## MON\_CLOSE (LED will indicate when an obstruction is detected or device is not present)

This input is only for the monitored entrapment protection device for the close direction. When the gate is closing, it will open to the full open position if an obstruction is sensed and resets the automatic close timer. This input does nothing in the opening direction. If a device is not connected or the board senses a fault (MON\_FAULT LED will turn on), the operator will only work with a constant pressure actuated switch. Once the obstruction is cleared, the gate will operate normally.

## MON\_OPEN (LED will indicate when an obstruction is detected or device is not present)

This input is only for the monitored entrapment protection device for the open direction. When the gate is opening, it will reverse for 2 seconds and stop if it senses an obstruction. This input does nothing in the closing direction. If a device is connected and the board detects a fault (MON\_FAULT LED will turn on), the operator will only work with a constant pressure actuated switch. Once the obstruction is cleared, the gate will operate normally.

# ALTERNATE MONITORED ENTRAPMENT PROTECTION DEVICE WIRING

ENFORCER E-960-D90GQ/ E-931-S33RRGQ / E-931-S50RRGQ	
CONTACT	BOARD TERMINAL
N.C.	MON_CLOSE OR MON_OPEN
COM	COMMON
12-30 VDC/AC	COMMON
12-30 VDC/AC	MON_12/24VDC

ENFORCER E-936-S45RRGQ	
WIRE	BOARD TERMINAL
BLACK	MON_CLOSE OR MON_OPEN
WHITE	COMMON
BLUE	COMMON
BROWN	MON_12/24VDC

ALLEN BRADLEY GRU-24	
WIRE	BOARD TERMINAL
BLACK	MON_CLOSE OR MON_OPEN
ORANGE	COMMON
BLUE	COMMON
BROWN	MON_12/24VDC

OMRON E3K-R10K4-NR		
SWITCH	CONTACT	BOARD TERMINAL
LIGHT ON	N.O.2	MON_CLOSE OR MON_OPEN
	C.2	COMMON
	24 TO 240 VAC	COMMON
	24 TO 240 VAC	MON_12/24VDC

EMX IRB-MON		
SWITCH	CONTACT	BOARD TERMINAL
SW1 - OFF	N.C.	MON_CLOSE OR MON_OPEN
SW2 - OFF	COM	COMMON
SW3 - ON	POWER/ VRX	COMMON
SW4 - OFF	POWER/ VRX	MON_12/24VDC

EMX IRB-325	
CONTACT	BOARD TERMINAL
N.C.	MON_CLOSE OR MON_OPEN
COM	COMMON
POWER	COMMON
POWER	MON_12/24VDC

EMX NIR-50-325	
WIRE	BOARD TERMINAL
BLACK	MON_CLOSE OR MON_OPEN
WHITE	COMMON
BLUE	COMMON
BROWN	MON_12/24VDC

EMX IRB-RET		
SWITCH	CONTACT	BOARD TERMINAL
SW1 - OFF	N.C.	MON_CLOSE OR MON_OPEN
SW2 - OFF	COM	COMMON
SW3 - OFF	POWER/ VRX	COMMON
SW4 - ON	POWER/ VRX	MON_12/24VDC

TRANSMITTER SOLUTIONS R50R-UL/R32P-UL/SR33HD/SR66HD	
CONTACT	BOARD TERMINAL
N.C. (3)	MON_CLOSE OR MON_OPEN
COM (5)	COMMON
NON POLARITY (1)	COMMON
12-30 VDC/AC (2)	MON_12/24VDC

TRANSMITTER SOLUTIONS iGAZE RE KIT		
SWITCH	CONTACT	BOARD TERMINAL
ALL OFF	N.C.1	MON_CLOSE OR MON_OPEN
	COM	COMMON
	(-) 12/24 VDC	COMMON
	(+) 12/24 VDC	MON_12/24VDC

EMX WEL-200	
CONTACT	BOARD TERMINAL
RELAY CLOSE (NC) RELAY OPEN (NC)	MON_CLOSE MON_OPEN
RELAY CLOSE (COM) RELAY OPEN (COM)	COMMON COMMON
POWER	COMMON
POWER	MON_12/24VDC

MILLER EDGE RBAND 6 WIRES FOR 1 EDGE - 8 WIRES FOR 2 EDGES		
SWITCH	CONTACT	BOARD TERMINAL
SW 1 - ON	N/C N/C	MON_CLOSE MON_OPEN
SW 2 - ON	COM COM	COMMON COMMON
SW 3 - ON	COM A.TEST	COMMON MON_12/24VDC
SW 4 - ON	12/24 (+) AC/DC	24-VDC GROUND

MON\_CLOSE = PROTECTS ACROSS THE DRIVEWAY/CLOSING DIRECTION  
 MON\_OPEN = PROTECTS THE REAR SLIDE / OPENING DIRECTION

# LOOP LAYOUT

- Below is a typical loop layout. When connecting to an All-O-Matic circuit board, use the following:
  - Safety Loop - Normally Closed (N.C) Contacts
  - Exit Loop - Normally Open (N.O.) Contacts
- Wires **MUST** be twisted from the exit point of the loop saw cut to the gate operator.
- Twist loop wires 6 turns per foot, as shown below. Improper twisting of wires can cause loop issues.
- When using an inside and outside safety loop, loops must be **WIRED IN SERIES**.

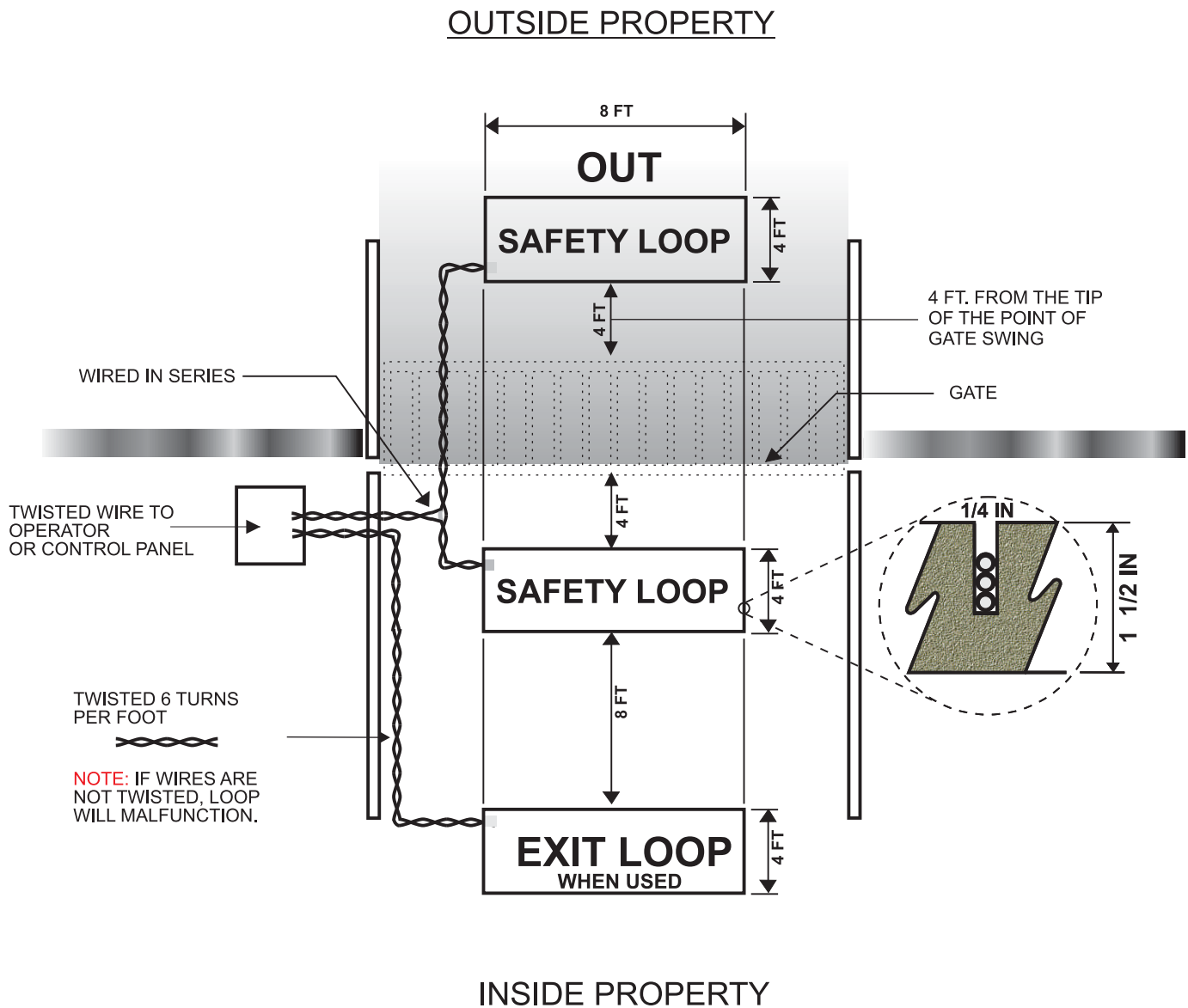

# PLUG IN DETECTOR INSTALLATION

- The OH-200DC PRO model comes equipped with the pre-wired LPR-2 loop rack for safety and exit plug in loop detectors, making installation quick and efficient.
- Hardwired loop detectors with harnesses can also be installed. The controller provides auxiliary 12 & 24VDC to power the detector of your choice. See "Accessory Connections" page for wiring instructions.
- Wire one or more safety devices in series with the loop rack wires. To do this, remove the white wire (N.C) from the loop rack off of the SAFETY terminal on the circuit board and wire nut to the COM of the additional device. The N.C. contact of the additional device will now go on the SAFETY terminal of the board.
- **IMPORTANT:** Use different frequencies for each loop detector to eliminate interference.

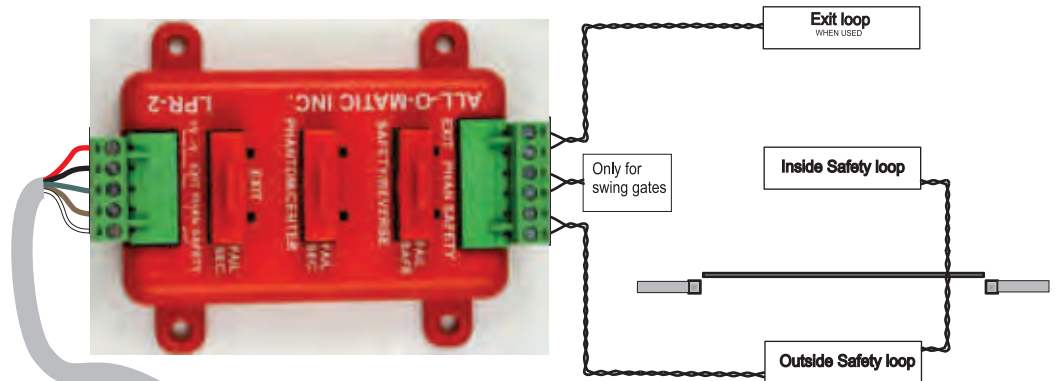

LOOP RACK	BLDC PRO BOARD	WIRE COLOR
+V	+12VDC	RED
-V	COMMON	BLACK
EXIT	EXIT LOOP	GREEN
PHAN	PHAN LOOP	ORANGE
SAFETY	SAFETY LOOP	WHITE

Remove Safety loop wire jumper when a SAFETY LOOP detector is installed.

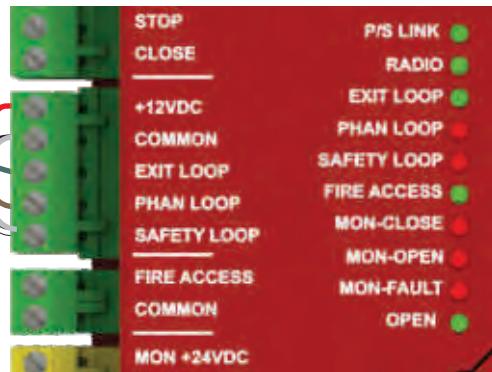

## PRIME-VD1

VEHICLE DETECTOR

### SETTINGS

SENSITIVITY	SW1	SW2
LOW	OFF	OFF
MEDIUM LOW	ON	OFF
MEDIUM HI	OFF	ON
HIGH	ON	ON

FREQUENCY	SW5	SW6
HIGH	OFF	OFF
MEDIUM HI	ON	OFF
MEDIUM LOW	OFF	ON
LOW	ON	ON

### INDICATORS:

RED - DETECT  
GREEN - PWR/LOOP FAIL

### GREEN LED BLINKING

INDICATE LOOP FAIL:  
1 BLINK - OPEN LOOP  
2 BLINKS - LOOP SHORTED

OUTPUT	SW3
N.O.	OFF
N.C.	ON

USE N.C. FOR SAFETY/  
REVERSE LOOP. N.O.  
FOR EXIT OR PHANTOM LOOPS.

PRESS RESET AFTER CHANGING SENSITIVITY AND FREQUENCY SETTINGS

OUTPUT	SW3
EXIT/PHANTOM	OFF
SAFETY	ON



# ACCESSORY WIRING

The **ALL-BLDC PRO** controller has auxiliary **+12VDC** and **+24VDC** terminals that provide up to 750mAmps on **+12VDC** and 750mAmps on **+24VDC** to power accessories. If the total current draw of the accessories exceeds the rated current for any of the +12VDC or +24VDC terminals, a separate power supply (transformer) is required.

**IMPORTANT:** From factory, we include wire jumpers on N.C. inputs. When installing a safety loop detector or a stop push button (**STOP** input), make sure to remove the wire jumper between the **COMMON** and **SAFETY LOOP** terminal for the safety detector and/or wire jumper between **STOP** and **COMMON** for a stop push button.

**AUX INPUT 1 AND AUX INPUT 2**, could be programmed to different functions. Depending on the function, the input can be N.O., N.C. or 10K termination for entrapment protection devices. See LCD display page for details on input function details.

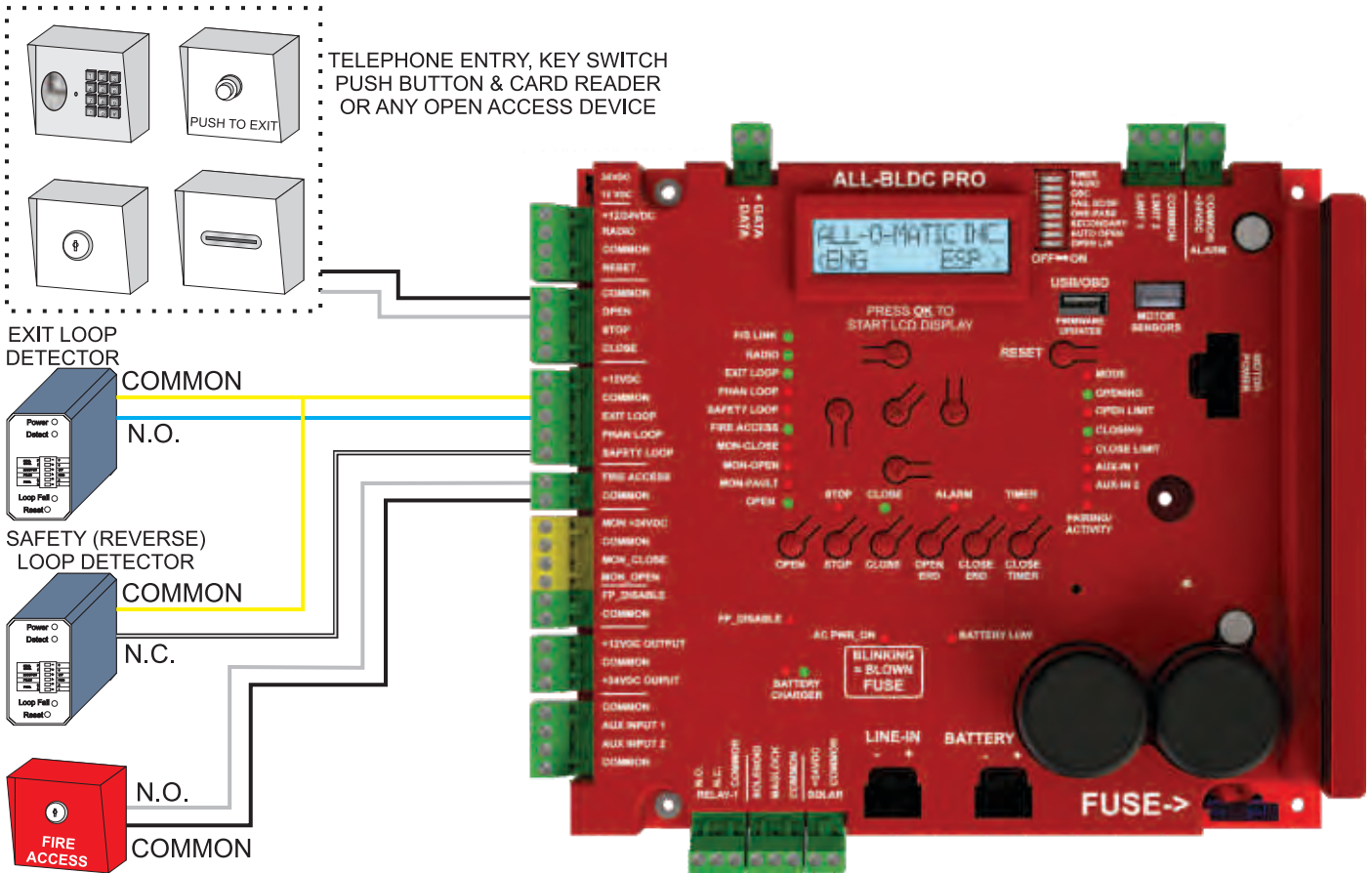

ALL-BLDC PRO controller has a built in delay of 0.5 seconds. Some locks may require longer delay to fully release. See auxiliary relay and delay page for details on setting a leaf delay and give the lock more time to release.  
NOTE: Delay can be set on either PRIMARY or SECONDARY operator.

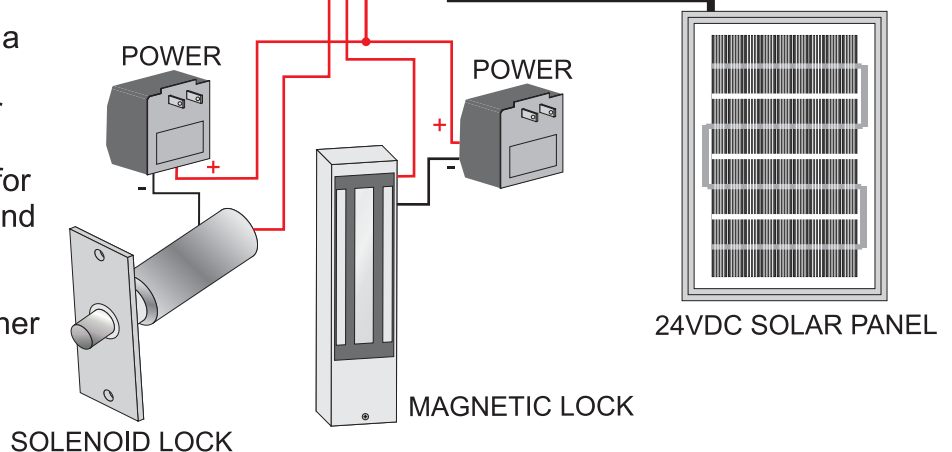

# ACCESSORY WIRING (CONT.)

- A three button station and reset push button are integrated on the board to make limit and ERD adjustments easier.
- An external three button station may also be installed. See diagram below for wiring instructions.
- **NOTE:** STOP jumper must be removed if a three button station is installed.

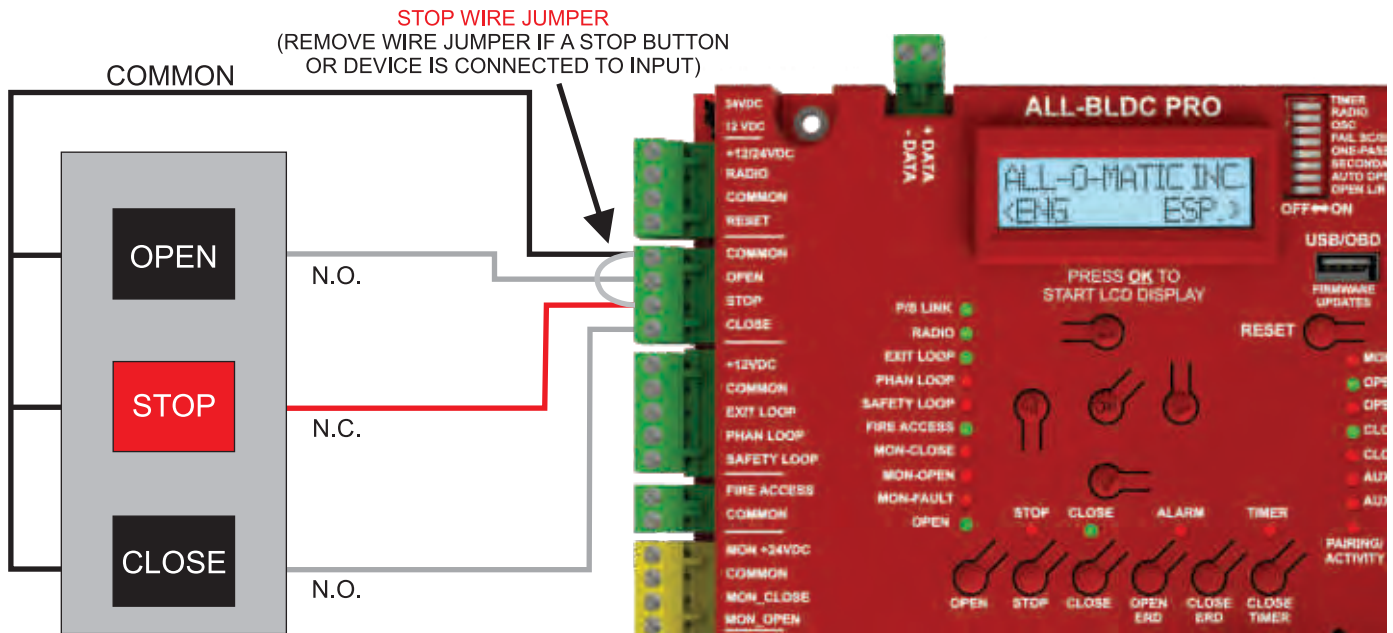

Magnetic or solenoid lock installation require a step down transformer with the appropriate voltage for the specific lock accessory. Most operators include a 120VAC outlet for the step down transformer. The **SL-45DC PRO** does not.

**Connections:** Plug power supply (transformer) to the 120VAC outlet receptacle. Connect one wire of from power supply low voltage directly to the lock device. The second low voltage wire from the power supply to board Lock relay COMMON terminal.

**For Magnetic Lock:** Connect second wire of the magnetic lock to MAGLOCK terminal of board lock relay.

**For Solenoid Lock:** Connect second wire of the solenoid lock to SOLENOID terminal of board lock relay.

See diagram for reference.

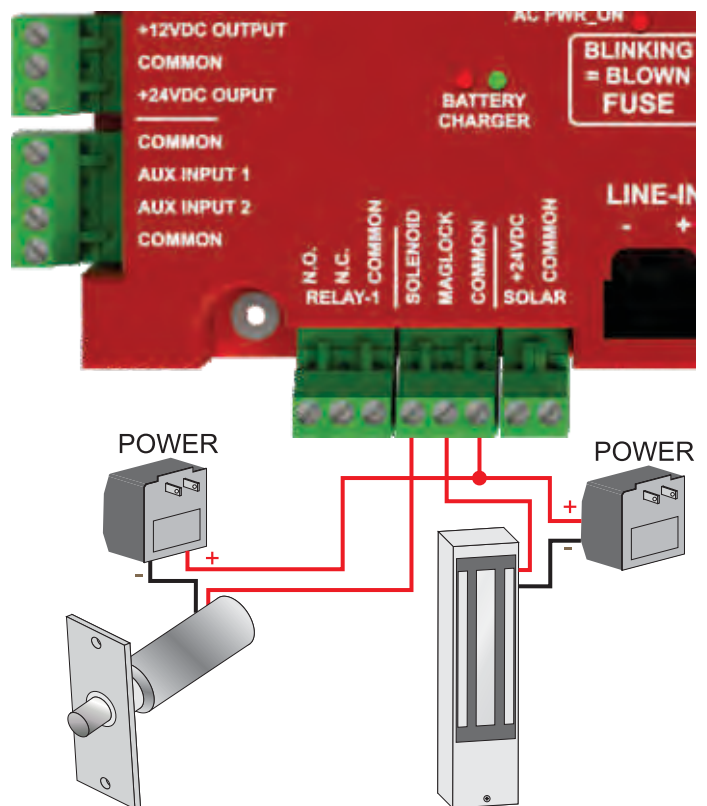

# SOLAR PANEL CONNECTION

The solar panel input requires a minimum of a 24VDC, 40 Watt panel. The charging circuit is capable up to 80 watt. With (2) 14Ah, 12VDC batteries, a receiver and (2) monitored entrapment devices connected, these operators can provide about 20 cycles/day.

Be sure to use the SOLAR input for solar panels. The on board solar battery regulator offers a MPPT feature that makes it more efficient than other types of regulators.

For a solar installation, upgrade the batteries according to usage. When the application requires more than 80 watts of solar power, an external charge controller regulator is necessary. See next page for external solar system.

For information on solar applications (solar panel sizes, battery size, etc.), please call All-O-Matic.



MPPT ON BOARD  
REGULATOR  
90+% EFFICIENCY

CONNECT BATTERY  
HARNES TO BATTERY  
PLUG ON THE BOARD

CONNECT 24V PANEL  
INTO SOLAR  
INPUT  
ON CIRCUIT BOARD.

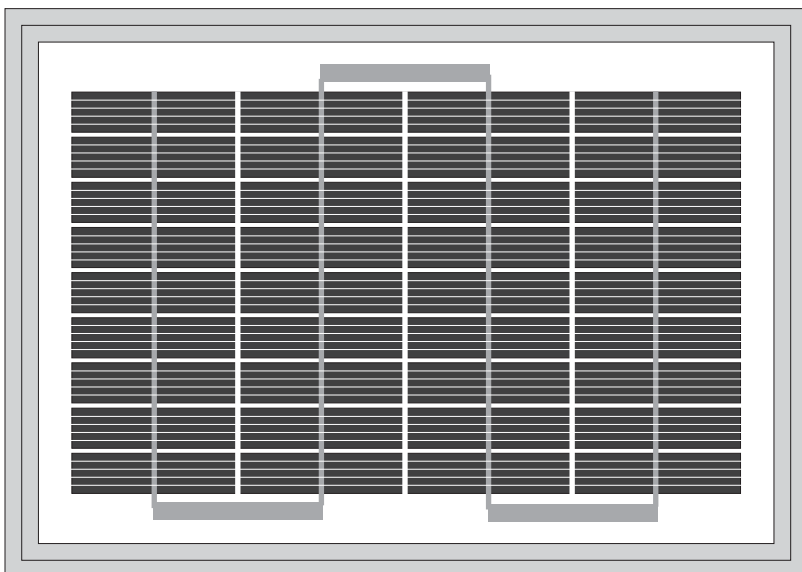

# EXTERNAL SOLAR SYSTEM INSTALLATION

When using an external solar package, connect batteries straight into the **BATTERY** input. The batteries will need to be upgraded to meet application requirements. See wiring below.

For information on solar applications (solar panel sizes, battery size, etc.), please call All-O-Matic.

**IMPORTANT:** When more than two solar panels are needed, special wiring precautions must be taken to prevent damage to batteries and/or charge controller regulator. If the panels are 12VDC they must be wired in series to make 24VDC. If 24VDC panels are used they must be wired in parallel.

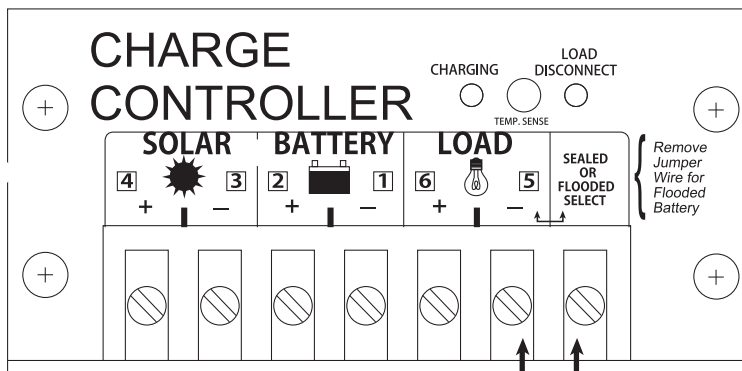

CONNECT BATTERY PLUG INTO BATTERY ON CIRCUIT BOARD

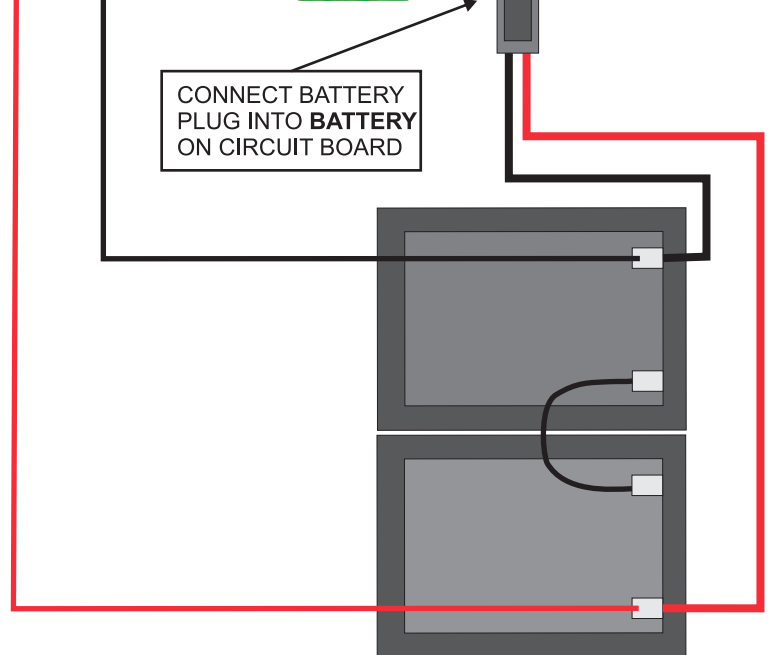
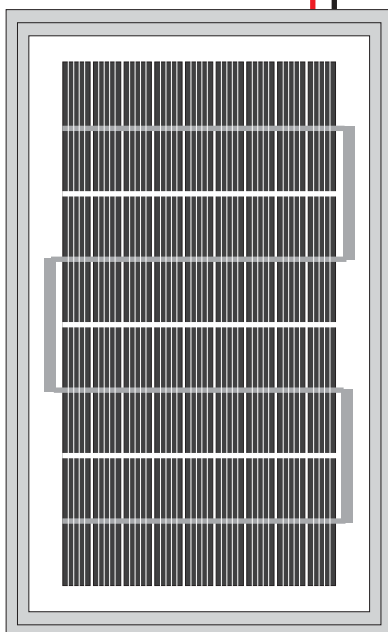

# LED DIAGNOSTICS

## P/S LINK

ON when primary/secondary communication is active.

## RADIO

ON when the RADIO input is activated (closed circuit to common).

## EXIT LOOP

ON when the EXIT input is activated (closed circuit to common).

## PHANTOM LOOP

ON when the PHANTOM LOOP input is activated (closed circuit to common).

## SAFETY LOOP

ON when the SAFETY LOOP input is activated (open circuit to common).

## FIRE ACCESS

ON when the FIRE ACCESS input is activated (closed circuit to common).

## MON\_CLOSE

ON when the MON\_CLOSE input is activated (open circuit to common) or when a device is not installed.

## MON\_OPEN

ON when the MON-OPEN input is activated (open circuit to common) or when a device is not installed.

## MON\_FAULT

ON when a fault has been detected on devices in MON-OPEN or MON-CLOSE inputs (if a device isn't working correctly or it isn't present).

## OPEN

ON when the OPEN inputs or OPEN push button are activated (closed circuit to common). It will be ON together with other inputs. See inputs page for more details.

## STOP

ON when the STOP input or STOP push button are activated (open circuit to common).

## CLOSE

ON when the CLOSE input or CLOSE push button are activated (closed circuit to common).

## ALARM

Turns on for 5 minutes (alarms also goes off) when the operator goes into shut down mode due to the gate hitting an obstruction (ERD) twice before reaching fully closed position.

## TIMER

Blinks every 1/2 second when the timer is counting down to close automatically.

## MODE

Blinks **once** every two seconds when there is a problem with the motor **sensor** feedback. Blinks twice every **two seconds** when a **motor overload** is detected. Blinks **three** times every two seconds when the gate is **jammed**.

## OPENING

ON while the gate is opening.

## OPEN-LIMIT

ON while the limit nut is activating the open limit switch.

## CLOSING

ON while the gate is closing.

## CLOSE-LIMIT

ON while the limit nut is activating the close limit switch.

## AUX-IN 1

ON while AUX INPUT 1 is activated (closed circuit to common).

## AUX-IN 2

ON while AUX INPUT 2 is activated (closed circuit to common).

## FP\_DISABLE

ON when the foot pedal is pressed down.

## AC/PWR ON

ON when AC power is on. It will also blink about every 1/2 second to indicate the main board fuse is blown.

## LOW-BATTERY

ON when the batteries are low, turned off or disconnected.

**TIPS:** When troubleshooting, it is important to note what lights are ON. It is very helpful to pay attention to the lights as they tell us what the board is doing and what inputs are active. When calling ALL-O-MATIC for technical support please have the name of the lights that are ON in the control board. This will speed up the process to get the gate operator up and running.

# TECHNICAL TIPS

Operator Symptom	Solutions (diganose)
Opening or closing LEDs are on, but gate doesn't move	If <b>AC PWR_LED</b> is blinking, replace the fuse at bottom right corner of the board. After replacing the fuse and before a signal is given, inspect the gate and make sure it's not bound up and that the limit switches are set correctly. If gate still doesn't run, check motor harness and make sure it is plugged in correctly and no wires are loose.
Radio receiver doesn't work	Jumper at top left corner by factory is set on 12VDC. If the receiver requires 24VDC, move the jumper to 24VDC.
AC PWR_ON LED is off	Make sure main high voltage power is connected and AC power switch is in the ON position. If that is fine, check 10Amp fuse in EMI board in the power box. If it's blown, check rectifier, it may also be damaged and need to be replaced along with the 10Amp fuse.
Gate opens very slow	Check limit switch adjustment. Usually when gate opens very slow it is due to gate hitting the receiving post or positive stop before close limit swith activates. Check the variable speed setting to be sure it's set at 100%. Check that the AC power is turned ON and that the AC PWR_ON LED is lit. Also, make sure limit learning has been done. See below.
Learning the limits for soft stop function.	Set the gate in closed position with the close limit activated. Press and release the RESET button on board. Run the gate a full cycle (full open and full close) without interruption. The first cycclle will be slower while learning the distance between limits. It will run full speed once limits have been learned.
Gate does not run and ALARM LED is ON	Gate is in Shut down mode due to obstruction detection. Press red RESET button outside control box next to radio connector. Run the gate and inspect gate is not bound up or jammed. Test ERD sensivity. See ERD adjusment page for details on the adjustment.
Gate does not run and FP_DISABLE is ON	Check foot pedel and make sure it's up. Foot pedal has a kill switch and when it's down, it disables the operator.
Gate does not run and STOP LED is ON	Check STOP input device and make sure it is not activated. Remember, this input is N.C. and LED will stay on if the wrong contact is used.
Gate does not run and MODE LED blinks	See LED DIAGNOSTICS for details on the meaning of the blinks.
Gate doesn't close	Check LEDs, any of the following input LEDs will prevent gate from closing. Check inputs for LEDs that are ON: RADIO, OPEN, STOP, EXIT LOOP, PHAN LOOP, SAFETY LOOP, FIRE ACCES, MON-CLOSE (check wiring and alignment), FP_DISABLE, (AUX INPUT 1 & 2, depending on programmed function). Also, check if AC PWR_ON LED is OFF(if it's OFF and dip-switch 4 or 7 are ON, gate will remain open).
Gate doesn't open	Check LEDs, any of the following input LEDs will prevent gate from opening. Check inputs for LEDs that are ON: STOP, CLOSE, MON-OPEN, FP-DISABLE and AUX INPUT 1 or 2 (depending on programmed fuction). Also, check if AC PWR_ON LED is OFF (if it's OFF and dip-switch 4 is OFF, gate will remain closed if battery is low)
Gate stops and reverses before reaching limits	Check ERD. If no obvious obstruction is present, it may need to be adjusted and increase the force for the direction it is stopping. See ERD adjustment page for details.
Gate stops and reverses open	Check LEDs and see if any of them turn ON when gate reverses. It may be that the gate movement might be activating that device. See above the devices that prevents gate from closing.

# AUX INPUT 1 & 2 PROGRAMMING

AUX INPUT 1 & 2 can be programmed to do different functions. Below are the options

## 1. AUX INPUT 1

- 1. EMERGENCY OPEN** (factory default)  
Devices connected to the input in this function, will open the gate and will override MON-OPEN devices. Use N.O. contact.
- 2. PARTIAL OPEN** (set partial open in %)  
Devices connected to this input in this function, will open the gate partially to set opening %. Use N.O. contact from device relay.
- 3. OPEN-CMD**  
Devices connected to this input in this function, will open the gate. Use N.O. contact from device
- 4. CLOSE-CMD**  
Devices connected to this input in this function, will close the gate. Use N.O. contact.
- 5. MON-OPEN**  
In this function, this input is an expansion for open direction entrapment protection devices. N.C. or 10K termination can be used on device.  
**IMPORTANT:** If N.C. termination is used, must use MON +24VDC to power device.
- 6. MON-CLOSE**  
In this function, this input is an expansion for close direction entrapment protection devices. N.C. or 10K termination can be used on device.  
**IMPORTANT:** If N.C. termination is used, must use MON +24VDC to power device.
- 7. STOP-CMD**  
Devices connected to this input in this function, will stop the gate. Use N.C. contact.

## 2. AUX INPUT 2

- 1. EMERGENCY CLOSE** (factory default)  
Devices connected to the input in this function, will close the gate and will override MON-CLOSE devices. Use N.O. contact.
- 2. PARTIAL OPEN** (set partial open in %)  
Devices connected to this input in this function, will open the gate partially to set opening %. Use N.O. contact from device relay.
- 3. OPEN-CMD**  
Devices connected to this input in this function, will open the gate. Use N.O. contact from device
- 4. CLOSE-CMD**  
Devices connected to this input in this function, will close the gate. Use N.O. contact.
- 5. MON-OPEN**  
In this function, this input is an expansion for open direction entrapment protection devices. N.C. or 10K termination can be used on device.  
**IMPORTANT:** If N.C. termination is used, must use MON +24VDC to power device.
- 6. MON-CLOSE**  
In this function, this input is an expansion for close direction entrapment protection devices. N.C. or 10K termination can be used on device.  
**IMPORTANT:** If N.C. termination is used, must use MON +24VDC to power device..
- 7. STOP-CMD**  
Devices connected to this input in this function, will stop the gate. Use N.O. contact.

See next page on details on how to navigate through LCD display menu to program desired function on AUX INPUT 1 & 2.

Connect device relay contacts to these two terminals. Relay COMMON to board COMMON. RELAY N.O., N.C. or 10K to AUX INPUT 1. The relay contact depends on the function. See above for contact options.

Connect device relay contacts to these two terminals. Relay COMMON to board COMMON. RELAY N.O., N.C. or 10K to AUX INPUT 2. The relay contact depends on the function. See above for contact options.

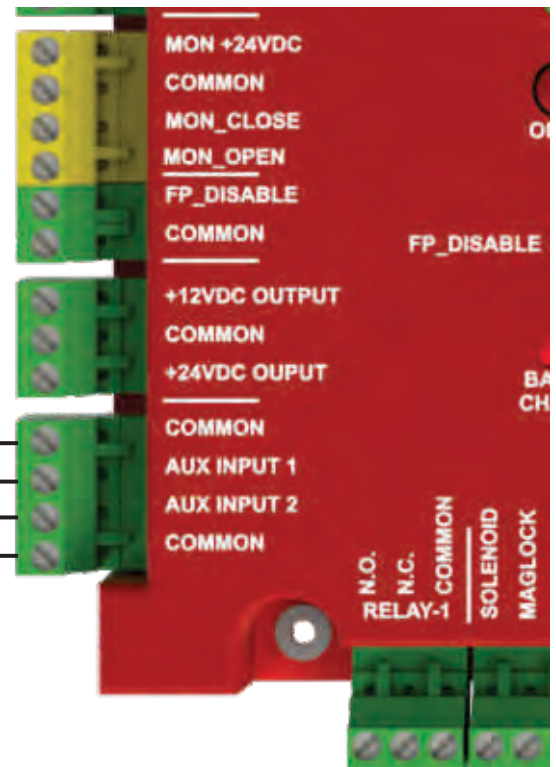

# LCD SETTINGS AND DIAGNOSTICS

These instructions will take you through the ALL-BLDC PRO board LCD display menu.

To wake up the display press the OK button a couple of times until you see the options for <ENG and ESP.>. For English press the <left button. For Spanish press the right button. Once language is selected, scroll to settings or diagnostics, and press OK to go into selection. Use up and down buttons to scroll and right or left to move cursor. OK button is to save or select menu items.

## 1.SETTINGS

### 1.TIME DATE

#### 1.TIME XX: XX AM

- 1.Press the OK button when the cursor on TIME.
- 2.Move the cursor with the left and right buttons to move between the hour, minutes, & AM/PM
- 3.Use the up and down buttons to adjust.
- 4.Once adjustment are made, press the OK button to save.

#### 2.DATE XX/XX/XXXX

- 1.Press the OK button when the cursor is on DATE.
- 2.Move the cursor with the left and right buttons to move between the month, day, and year.
- 3.Use the up and down buttons to adjust.
- 4.Once the adjustment is made, press the OK button to save them.

### 2.SPEED

#### 1.MAX SPEED 100%

- 1.This is for adjusting the motor maximum run speed.

#### 2.ACCELERATION FST

- 1.This is for adjusting how fast the motor ramps up.

#### 3.SLOW DOWN 2 FEET

- 1.This is for adjusting when the motor will start to slow down as it approaches a Limit Switch..

### 3.POWER

#### 1.CURR. SENSE PRGV

- 1.This is for adjusting how responsive the ERD is..
- 2.Options are Progressive and Threshold
- 3.The threshold is the most responsive (sensitive)

#### 2.ERD

- 1.OPEN ERD (this can be accessed directly with quick access OPEN ERD button)
  - a.This is for adjusting Opening ERD force.
- 2.CLOSE ERD (this can be accessed directly with quick access CLOSE ERD button)
  - a.This is for adjusting Closing ERD force.

### 4.7/DAY TIMER

#### 1.EVENT 1-10

- 1.Each event has active and deactivate time settings for each of the Event Actions.

#### 2.Options for the Event Actions.

- a.OPEN
- b.CLOSE
- c.AUXILIARY RELAY

### 5.LEAF DELAY

#### 1.DELAY CLOSE

- 1.Select if the delay is for OPEN or CLOSE
- 2.Mainly for swing gates that overlap

#### 2.DELAY 00.0 SEC

- 1.Here is to set the delay in seconds.

### 6.PRE-WARN ALARM (this uses the built in audible alarm to turn on when gate is in motion)

#### 1.ALARM OFF

- 1.Set it ON or OFF here.

#### 2.DELAY 00.0 SEC

- 1.Set the delay here.
- 2.Range is from 0-12 seconds.

### 7.AUXILIARY RELAY (below are the options of relay activation)

#### 1.OFF (INACTIVE)\*

#### 2.PRE-WARN SIGNAL (this is similar to the PRE-WARN ALARM function)

#### 3.MOVING SIGNAL (this function turns ON the auxiliary relay while the gate is moving)

#### 4.OPENED SIGNAL (relay activates when gate is fully opened)

#### 5.CLOSED SIGNAL (relay activates when gate is fully closed)

#### 6.PULSE ON OPEN (relay does a 1 second pulse when open limit activates)

### 8.AUXILIARY INPUT (input 1 has the EMERGENCY OPEN and input 2 has the EMERGENCY CLOSE)

#### 1.AUX INPUT 1-2

- 1.EMERGENCY OPEN/CLOSE \* (this function will override the monitored open/close input and allow the gate to fully open/close)

#### 2.PARTIAL OPEN (this function is to open the gate partially with opening percentage setting)

#### 3.OPEN\_CMD (this will work identical to the other open inputs)

#### 4.CLOSE\_CMD (this will work identical to the CLOSE input)

#### 5.MON-OPEN (this is an expansion to the MON-OPEN input)

#### 6.MON-CLOSE (this is an expansion to the MON-CLOSE input)

#### 7.STOP\_CMD (this will work identical to the STOP input)

### 9.SERVICE CYCLE (this will provide a planned service call based on run cycles)

#### 1.SERVICE CYCLE

- 1.Program the number of cycles the gate needs to run before the next preventive maintenance service call.

- 2.When programmed, the board will start the count down. When it gets to zero, it will start beeping to alert the end user it's time to call for service.

- 3.Technician can reset in diagnostics cycle count

# LCD SETTINGS AND DIAGNOSTICS (CONT.)

- 2.COUNT 00000
  - 1.Use <right and left> buttons to move the cursor to tens, hundreds, thousands and 10 thousands position.
  - 2.Use UP and DOWN buttons to adjust the value
- 10.AUTO CLOSE TIMER
  - 1.AUTO CLOSE TIMER (this can be accessed with the quick access TIMER push button)
  - 2.SET DELAY: 005 (delay is adjustable from 0-120 seconds)
- 11.SETTINGS CHG LOG (this will keep a log of the last 3 times the settings were adjusted/changed)
  - 1. 01. SETTINGS CHG
  - 2. XX/XX/XX 00:00AM
    - 1.It will save the date and time.
- 12.FIRMWARE UPDATE (firmware could be upgraded in the field)
  - 1.PLUG IN A THUMB DRIVE
    - 1.This is to update firmware in the field if necessary. AOM can provide the BIN file via email, the installer can then mount it into a thumb drive to then plug it in the board USB input to do the update.
    - 2.The thumb drive must be formatted to FAT, FAT16 or FAT32 to be readable by the board.
- 13.WIRELESS SETUP (when wireless PRIMARY/SECONDARY is used and there are other operators nearby using the same communication, it will be necessary for the different systems to have unique channels. This is where channels can be changed. There are 8 channels to choose from)
  - 1.WIRELESS CHANNEL
    - 1.Make sure the pair of operators are set to the same channel.
- 14.SET TO DEFAULT (Set individual or all settings to factory default)
  - 1.DEFAUL ALL
  - 2.DEFAULT SPEED
  - 3.DEFAULT POWER
  - 4.DEFAULT 7/D TMR
  - 5.DEFAULT LEAF DLY
  - 6.DEFAULT PRE ALRM
  - 7.DEFAULT AUX RLY
  - 8.DEFAULT AUX INS
  - 9.DEFAULT SVC CYC
  - 10.DEFAULT AUTO CLS
  - 11.DEFAULT WIRELESS

## 1.DIAGNOSTICS

- 1.GATE STATUS
  - 1.CLOSED, OPENED OR STOPPED STATUS
- 2.METER (this provides voltage readings from the BATTERY and LINE IN inputs)
  - 1.BATT VOLTAGE
  - 2.LINE IN VOLTAGE
- 3.MOTOR (this provides the motor speed and the gate travel in percentage)
  - 1.MOTOR SPEED
  - 2.TRAVEL
- 4.LAST EVENT (this displays the last event that was recorded)
  - 1. 50. (LAST LOGGED EVENT NAME)
  - 2. XX/XX/XX 00:00PM (LAST EVENT TIME & DATE)
- 5.EVENT LOG (this provides the event log; it can store up to 50 special events)
  - 1.1-50 LOGGED EVENTS
- 6.CYCLE COUNT (this provides the cycle count of the unit; including the service cycle count in case one was programmed)
  - 1.LIFE CYCLES
  - 2.MONTH CYCLES
  - 3.DAY CYCLES
  - 4.SERVICE CYCLES (the service cycle count will be displayed and will show the option to reset if it has reached the zero count)
- 7.EXPORT TO USB
  - 1.PLUG IN A THUMB DRIVE
    - 1.This allows the settings and diagnostic data to be exported to a thumb drive to view on a smartphone or pc; thumb drive must be formatted to FAT, FAT16 or FAT32 in order to work.

# EMERGENCY RELEASE INSTRUCTIONS

Make sure the gate is in the full open position to prevent the gate from coming down if it is not well balanced.

To manually release the gate from the operator:

- Move the locking latch to the side
- Pull the release ring downward
- Slide the latch with the slit backward to disengage it from the lock pin.

**NOTE:** To avoid serious injury, only disengage the gate when it is clear of people and obstructions.

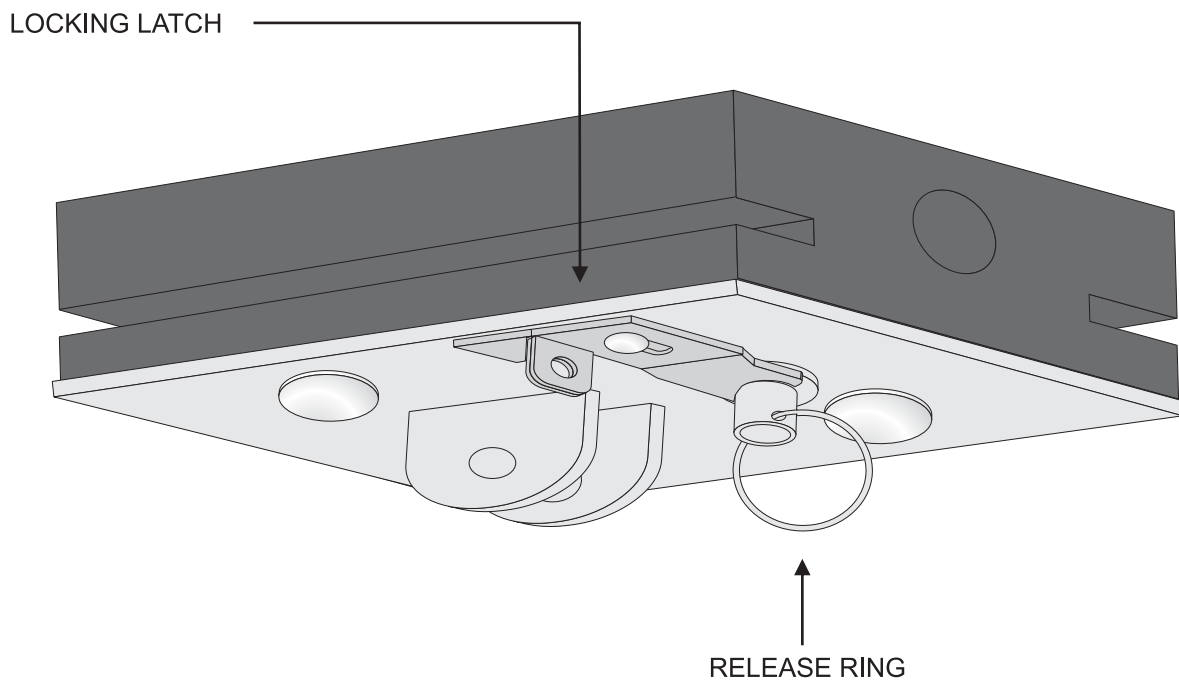

# BREATHER CAP PIN

**NOTE:** After operator installation, remove the breather cap pin from the gear box to allow the gearbox to breath and avoid seal outward pressure.

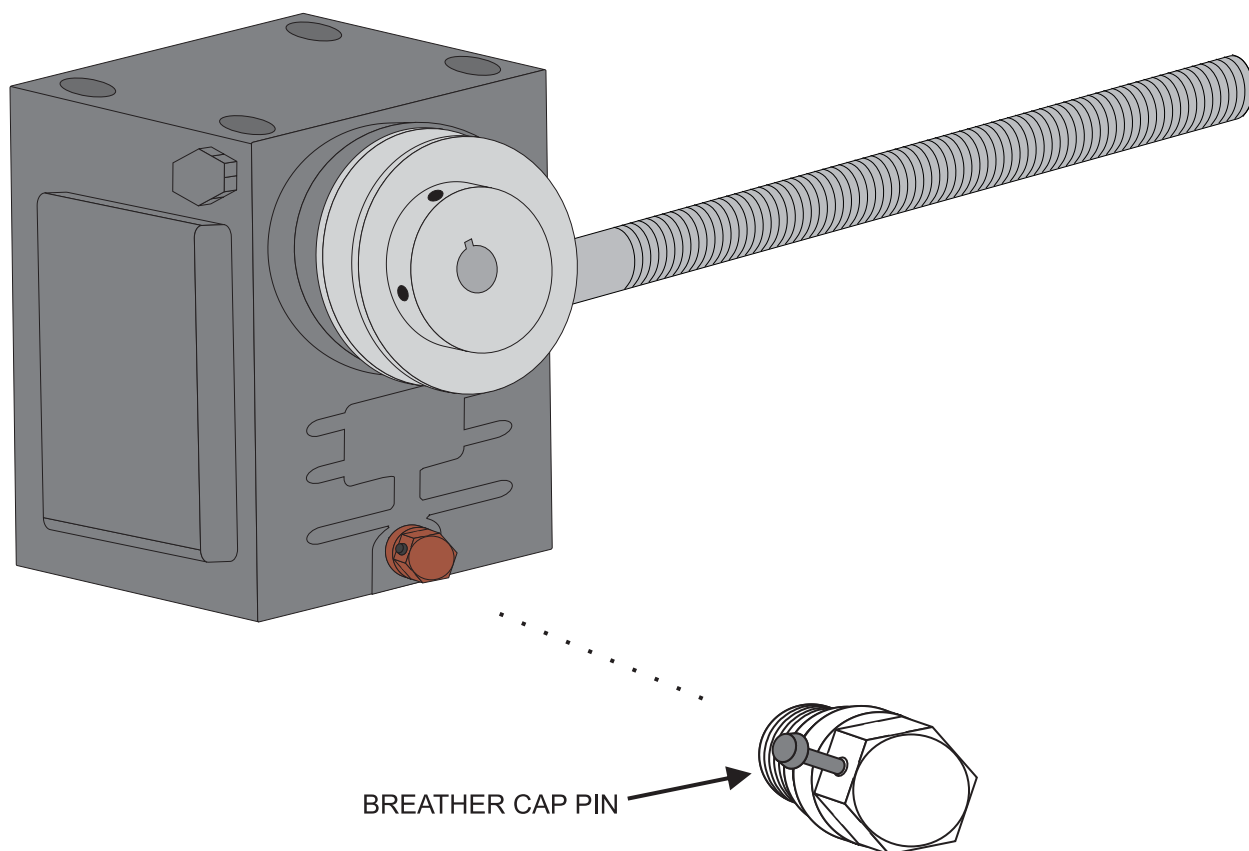

# WARRANTY AND RECORD

## MANUFACTURER'S LIMITED WARRANTY

**ALL-O-MATIC INC** warrants the following gate operator OH-200DC PRO for a period of five (5) years in commercial installations. The above operator, within its warranty period, is to be free from defects in circuitry, motor, gearbox and workmanship. This warranty begins from the date of purchase to the original owner. Warrantor will repair or, at its option, replace any device which it finds to require service. This device must be sent to the warrantor at the consumer's expense to:

**ALL-O-MATIC INC.  
7658 HASKELL AVE.  
VAN NUYS, CA 91406**

The warrantor will return the repaired or replaced unit to the customer at the consumer's expense. Labor charges for dealer service or replacement are the responsibility of the owner. These warranties are in lieu of all other warranties either expressed or implied, and ALL-O-MATIC INC shall not be liable for consequential damage. All implied warranties of merchantability and or fitness for a particular purpose are hereby disclaimed and excluded. This limitation is not valid in jurisdictions which do not allow limitation of incidental or consequential damages or limitation of warranty periods. In order to obtain this policy, please complete the registration card and send it by mail within 30 days of purchasing from ALL-O-MATIC INC. or your installer. If the product is not registered, only a one year warranty on all parts will be provided.

## CUSTOMER RECORD

Customer Name \_\_\_\_\_

Address \_\_\_\_\_

Purchased from (Installation Co.) \_\_\_\_\_

Date \_\_\_\_\_

Model Number \_\_\_\_\_

Serial Number \_\_\_\_\_ - \_\_\_\_\_



# ALL-O-MATIC<sup>®</sup>

MANUAL

UL 325 & UL991  
COMPLIANT

CANADA  
CSA C22.2  
COMPLIANT